

HM-60A User Guide



HIMODEL CO., LTD

[HTTP://WWW.HIMODEL.COM](http://www.himodel.com)

HM-60A

By HiModel RC Hobby
60Amp Brushless Sensorless Speed Controller

Warning! High power motor systems can be very dangerous! High currents can heat wires and batteries, causing fires and burning skin. Follow the wiring directions carefully! Model aircraft equipped with high power motors can kill. Always fly at a sanctioned field. Never fly over or near spectators. Even though this controller is equipped with a safety arming program, you should still use caution when connecting the main battery.

Dear customer,

Congratulations on your choice of a HIMODEL'S *HM-60A* 60Amp continual brushless sensorless speed controller, which is a micro-computer controlled unit developed and manufactured entirely in CHINA, designed for brushless sensorless 3-phase rotary current motor only.

The intelligent programming system makes it as simple as possible to configure the controller to match any radio control system and brushless motor type. Depend on the skillful and powerful software, the unit have some special features which make the player feel free and cool.

We wish you joy and a lot of success with your new HIMODEL Electronic Speed Controller.

We strongly recommend getting particularly close attention to the safety instruction include those who hate read instructions!

Best regards,

HM-60A

By HiModel RC Hobby

60Amp Brushless Sensorless Speed Controller

Warning! High power motor systems can be very dangerous! High currents can heat wires and batteries, causing fires and burning skin. Follow the wiring directions carefully! Model aircraft equipped with high power motors can kill. Always fly at a sanctioned field. Never fly over or near spectators. Even though this controller is equipped with a safety arming program, you should still use caution when connecting the main battery.

Contents

Chapter Subject	page
1.0 Safety and operating instructions	4
2.0 Limitation of liability	5
3.0 Features of the <i>HM-60A</i>	6
4.0 Wiring your <i>HM-60A</i>	7
4.1 Servo Ratings with BEC Enabled	
4.2 Adding the Battery Connector	
4.3 Connecting the Motor	
4.4 Reversing Rotation	
4.5 Connecting the Receiver	
5.0 Using your <i>HM-60A</i> in the first time	9
6.0 Flying with Your <i>HM-60A</i>	10
7.0 Using the Programming Features of <i>HM-60A</i>	11
8.0 <i>HM-60A</i> Programming Features	12
9.0 Entering Programming Mode	13
10.0 Programming the <i>HM-60A</i>	14
11.0 Troubleshooting	16
12.0 Contact / Warranty Information	16

HM-60A

By HiModel RC Hobby
60Amp Brushless Sensorless Speed Controller

Warning! High power motor systems can be very dangerous! High currents can heat wires and batteries, causing fires and burning skin. Follow the wiring directions carefully! Model aircraft equipped with high power motors can kill. Always fly at a sanctioned field. Never fly over or near spectators. Even though this controller is equipped with a safety arming program, you should still use caution when connecting the main battery.

1.0 Safety and operating instructions

Building and operating R/C aircraft models required special technical knowledge by careful and safety handling. Incorrect assemble as well as carelessly using can result in significant property and/or personal injuries. For these reasons building and operating the instructions correctly and carefully, when mounting and operating a aircraft model with Electronic Speed Controller.

The HIMODEL's *HM-60A* is developed exclusively for R/C model applications, DON'T USED IN ANY MAN-CARRYING AIRCRAFTS OR ANY OTHER MAN-CARRYING MACHINES.

The *HM-60A* is designed for exclusive operating with batteries(Ni-MH or Li-XX). Never use the unit by connecting to a power supply, when motor breaks an over voltage by energy return appears, which could destroy supply and *HM-60A* unit. Never connect *HM-60A* unit or other propulsion components directly to the 110V/AC or 230V/AC current.

In any case keep your body and any other objects away from the path of a propeller or other spinning motor parts, which is connected to a power battery. Although *HM-60A* have a feature of safe "power on", take careful is important. Never lean over a running system. Care about that no parts can come in touch with spinning drive parts, they could be thrown into your face, and could also weaken propeller and driver, causing mechanical or electric failures. Protect yourselves against any dangers coming from propellers and helicopter rotors. Keep anybody, especially small children, who can be hurt when the engine is running, at least 20 feet (about 6 meters) away.

Protect the *HM-60A* unit against any vibrations, dust, wet, hits or pressures. Check the unit regularly on damages. Should the device have become wet, only reuse it again after doing a longer drying phase and an exact examination! Also *HM-60A* unit has to be completely checked after any model crash. Never use a damaged *HM-60A* unit!

Use device only by outside temperatures between -10°C (50°F) up to 50°C (122°F). Therefore always provide the unit for a good cooling. *HM-60A* operations are only permitted in no electrostatic surroundings, where no loading can come true.

HIMODEL's *HM-60A* unit is not protected against polarity reversions, therefore you must be sure that polarity is correct when connecting the *HM-60A* unit. If you connection is wrong way round it could cause destruction of the device. If you want to reverse the motor rotation, bench test the motor connetions noting the rotation of the motor. To change the rotation of the motor, simply swap any two wires connections or do it by programming. Never reverse battery connecting leads. Never connect power battery wires directly to the engine ones. This also can cause destruction of a device.

Never separate the battery from the *HM-60A* when motor is running. This can cause high

HM-60A

By HiModel RC Hobby
60Amp Brushless Sensorless Speed Controller

Warning! High power motor systems can be very dangerous! High currents can heat wires and batteries, causing fires and burning skin. Follow the wiring directions carefully! Model aircraft equipped with high power motors can kill. Always fly at a sanctioned field. Never fly over or near spectators. Even though this controller is equipped with a safety arming program, you should still use caution when connecting the main battery.

current drains which can cause device destruction. Some BEC types are fitted out with a switch. Don't disconnect the power batteries from the **HM-60A** unit. A low residual current flows even if the switch position is OFF (AUS), this will cause deep under loading especially by Lion/LiPo-cells applications! Therefore connect the batteries to the **HM-60A** unit a few seconds before operating, and disconnect them immediately after the end of run.

Never connect a receiver battery in parallel when using BEC device. This will cause destruction of the BEC device! If you want to get a separate receiver battery by BEC type use, than disconnect and take out the red wire from the receiver-lead(3p wires). The free connector has to be insulated with a bit of electrical tape. Like this the BEC unit is out of service and a receiver battery can be connected without any danger. To know the permissible BEC load, which depends of the cells number and type of the battery pack, we have a capacities list in below. Attention digital Micro servos get a very high current drain, that means that the indicated number of Servos has, if necessary, to be decreased.

Mount your radio equipment, especially the receiver with its antenna, as far as possible from **HM-60A** unit, batteries and motor. Otherwise, high current magnetic fields could affect the receiving quality. Always do a range test with low speed running motor, to make sure the perfect receiving function of your model.

For any connection you should use good contact plugs and sockets which must be soldered perfectly to the wires. Never use strip connectors, crimp connectors or similar.

Connect **HM-60A** unit lead into the throttle channel on your receiver. Don't operate **HM-60A** by a servo tester, because it could happened that motor will do some short starts in reason of some incorrect "throttle impulses". For this we strongly recommend to only using receivers from relevant and reliable manufactories!

HIMODEL's **HM-60A** units are equipped with some extensive protection devices, which can only protect when operating in a "normal" range. For example if you get a motor winding or a wire short cut or something similar, **HM-60A** unit could be damaged or destroyed.

2.0 Limitation of liability

In that HIMODEL has no control over the correct use, installation, application, as well as the **HM-60A** maintenance, no liability shall be assumed nor accepted for any damages, losses or costs resulting from the use of the product. Any claims arising from the operating, failure or malfunctioning etc. will be avoided. HIMODEL assumes no liability for personal injury, property damage or consequential damages resulting from our delivery or our workmanship. As far as is legally admitted, with which legal arguments ever, the obligation to the compensation is limited to the invoice amount of the affected product. This does not apply, as far as we must avouch unrestrictedly after compelling laws or for rough negligence.

HM-60A

By HiModel RC Hobby

60Amp Brushless Sensorless Speed Controller

Warning! High power motor systems can be very dangerous! High currents can heat wires and batteries, causing fires and burning skin. Follow the wiring directions carefully! Model aircraft equipped with high power motors can kill. Always fly at a sanctioned field. Never fly over or near spectators. Even though this controller is equipped with a safety arming program, you should still use caution when connecting the main battery.

3.0 Features of the HM-60A:

HM-60A unit is a highly developed electronic device, which can through setting different operating modes to make compatible to various type of brushless motors. This compact dimensions and light weight make it is a good choice for small aircraft model.

Into all these different types, which are individually described below, you will found the correct programming for any purposed model application.

The **HM-60A** has so many powerful feature:

- High rate (10 KHz) switching (PWM)
- Up to 60 Amps continuous current with proper air flow, 135amps surge (>15s)
- Ten to twelve Ni-MH cells or three LiXX cells with receiver
- Up to ten Ni-MH cells or three LiXX cells with four micro servos (Max. 3 amp BEC)
- Twenty Ni-MH(24v) or six LiXX cells (3.7*6=22.2v)MAX (with BEC disabled)
- Dynamic braking ensures folding props fold promptly
- BEC (3.0A) provides power to receiver and servos -eliminates separate receiver battery
- Over temperature protection
- User Programmable Features(by throttle pole programmable or by computer programmable)
 - Low-voltage protection can programming the value of low-voltage and can choice cutoff current or reduce power
 - Over-current protection
 - Brake Type
 - Throttle Range
 - Timing Advance
 - Safe “power on” arming program ensures motor will not accidentally turn on
 - Low torque “soft start” prevents damage to fragile gearboxes
 - Auto shut down in 4sec after when signal is lost or radio interference becomes severe
 - Microprocessor controlled
 - Change the rotation by programming

HM-60A

By HiModel RC Hobby
60Amp Brushless Sensorless Speed Controller

Warning! High power motor systems can be very dangerous! High currents can heat wires and batteries, causing fires and burning skin. Follow the wiring directions carefully! Model aircraft equipped with high power motors can kill. Always fly at a sanctioned field. Never fly over or near spectators. Even though this controller is equipped with a safety arming program, you should still use caution when connecting the main battery.

4.0 Wiring Your HM-60A:

Tools required:

(1.)Wire cutters (2.)Wire strippers (optional) (3.)Soldering Iron (25-40)

Parts required:

(1.)Solder (rosin core “electronic” solder) (2.)Battery connector

4.1 Servo Ratings with BEC Enabled

Servo Type	9-10 cells(>10v)	11-12 cells(<15v)
Standard (micro) servos	5	4
High Torque servos	4	3

4.2 Adding the Battery Connector

The battery connector is attached to the side of the controller that has only two power wires(black and red), and also has the radio connector. Cut the wires to the length you require on the battery side. Strip off of the wire insulation to expose just enough wire to attach the battery connector. (Note: if you do not have a pair of wire strippers, you can use a modeling knife to careful cut through the insulation around the wire.) Attach the battery connector to the wires **ENSURING THAT THE POLARITY** (red wire to battery red wire, black wire to battery black wire) **IS CORRECT**, following the instructions for the battery connector.

IMPORTANT NOTE: YOU MUST BE SURE THAT THE POLARITY IS CORRECT WHEN CONNECTING THE SPEED CONTROLLER. INCORRECT POLARITY COULD PERMANENTLY DAMAGE THE CONTROLLER.

4.3 Connecting the Motor

The motor is connected to the side of the controller that has **THREE** power wires. Cut the wires to the length you require on the motor side. **DO NOT CUT** the wires leading from the motor. Strip the wire insulation to expose just enough wire to solder the wires to the motor terminals. There should be three wires extending from the motor. Connect the three speed control wires to the three motor wires. Align the wires carefully and solder to the motor wires. Ensure that all connections (battery and motor) are correctly polarized.

4.4 Reversing Rotation

Bench test the motor connections noting the rotation of the motor. To change the rotation of the motor, you can swap any two motor wire connections or programming in the mount face (that a new feature of HIMODEL’s ESC).

HM-60A

By HiModel RC Hobby

60Amp Brushless Sensorless Speed Controller

Warning! High power motor systems can be very dangerous! High currents can heat wires and batteries, causing fires and burning skin. Follow the wiring directions carefully! Model aircraft equipped with high power motors can kill. Always fly at a sanctioned field. Never fly over or near spectators. Even though this controller is equipped with a safety arming program, you should still use caution when connecting the main battery.

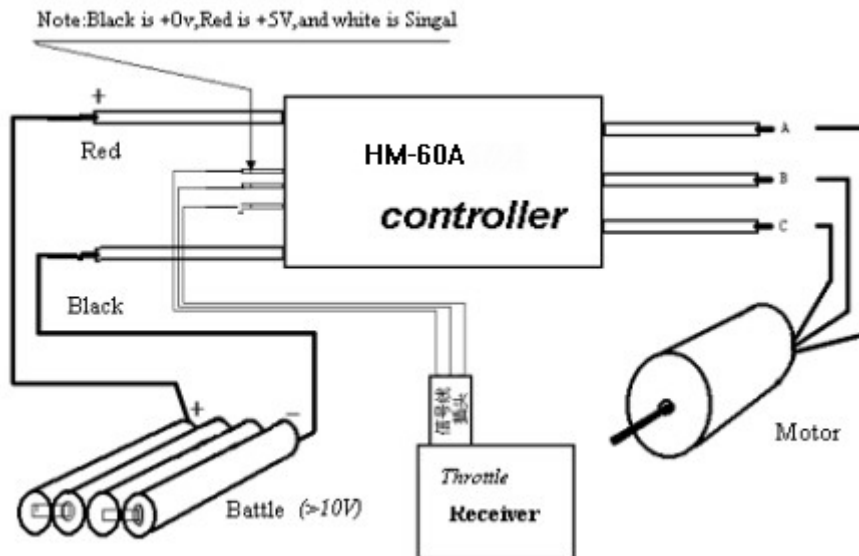

Fig 1: Motor, Battle and Receiver wiring diagram

Key to illustration:

Receiver cable, 3-pin

- =negative	black or brown
+ =positive	red
p =pulse	white or orange
battery connection neg. (-)	black
battery connection pos. (+)	red
motor connection a	red or yellow
motor connection b	red or yellow
motor connection c	red or yellow

4.5 Connecting the Receiver

Connect the receiver lead (the three color twisted wires with a connector on the end) to the throttle channel on your receiver. Do not connect a battery to the receiver, as the **HM-60A** will supply power to the receiver and servos through the receiver connector. If you are using more than twelve cells, you must use a separate receiver battery. See the section 7.0 (under the heading BEC) for instructions on disabling the BEC to use a separate receiver battery.

HM-60A

By HiModel RC Hobby

60Amp Brushless Sensorless Speed Controller

Warning! High power motor systems can be very dangerous! High currents can heat wires and batteries, causing fires and burning skin. Follow the wiring directions carefully! Model aircraft equipped with high power motors can kill. Always fly at a sanctioned field. Never fly over or near spectators. Even though this controller is equipped with a safety arming program, you should still use caution when connecting the main battery.

5.0 Using your HM-60A in the first time

We design the **HM-60A** controller only for brushless motor use, which can adapt for many type batteries, brushless motor, receiver and propeller. You must know it can not suit all type of that which your want to choice, so, please check your choice and test your system first. That help you do not make a mistake decision.

The intelligent programming systems make the **HM-60A** controller powerful and flexible, such in the start-up procedure, other controllers always make the propeller turn wrong way first then change it, but the **HM-60A** controller provide a new arithmetic will make the propeller turn right way in the start.

A single beep mostly indicates that the controller is armed! When you next move the throttle stick, the motor will start running. If the **HM-60A** beeps twice when the transmitter stick is at the brake position, you must disconnect the controller and operate the servo reverse facility on your transmitter, otherwise the controller would arm itself (single beep) at the full-throttle setting of your transmitter and would run at full throttle with the stick at the “stopped” position-the exact opposite of what is required.

We advice you testing your system first, and make sure your system is safety and effective.

HM-60A

By HiModel RC Hobby
60Amp Brushless Sensorless Speed Controller

Warning! High power motor systems can be very dangerous! High currents can heat wires and batteries, causing fires and burning skin. Follow the wiring directions carefully! Model aircraft equipped with high power motors can kill. Always fly at a sanctioned field. Never fly over or near spectators. Even though this controller is equipped with a safety arming program, you should still use caution when connecting the main battery.

6.0 Flying with Your HM-60A:

ALWAYS PERFORM A RANGE CHECK BEFORE FLYING WITH ANY NEW SPEED CONTROLLER! PERFORM YOUR RANGE CHECK AT FULL THROTTLE, HALF THROTTLE AND NO THROTTLE.

Initialization sequence:

- 6.1 Connect the speed controller receiver connector to the proper channel on your receiver.**
- 6.2 Turn on your transmitter, and set the throttle to closed or lowest position.**
- 6.3 Connect the main power battery to the speed controller, you must hear a “beep” , and the LED “flashed” one time.**
- 6.4 The speed controller will remain disarmed (will not operate) until it sees more than two seconds of “brake” throttle. Then you will hear a “beep ” or double “beep”, at the same time, the LED will “flashed” one time or two times. One “beep” and one “flashed” means no brake, double “beep” and two “flashed” means have brake.**
- 6.5 Go fly!**

If the BEC cutoff occurs when you flying, you must put the throttle to the lowest position, then restart the motor and use low throttle, land your model as soon as you can. Check your batteries' voltage, BEC cutoff will occur again if the voltage drops too low.

HM-60A

By HiModel RC Hobby
60Amp Brushless Sensorless Speed Controller

Warning! High power motor systems can be very dangerous! High currents can heat wires and batteries, causing fires and burning skin. Follow the wiring directions carefully! Model aircraft equipped with high power motors can kill. Always fly at a sanctioned field. Never fly over or near spectators. Even though this controller is equipped with a safety arming program, you should still use caution when connecting the main battery.

7.0 Using the Features of Your HM-60A:

BEC -The BEC power is supplied to the receiver and servos through the receiver connector wires. If you wish to disable the BEC and use a separate receiver battery, you must first cut the red wire in the trio of receiver wires. Simply use a pair of wire cutters to remove a short section of the red wire near the receiver connector, and be sure to insulate the cut wire with a bit of electrical tape. Then you may safely use a battery with your receiver.

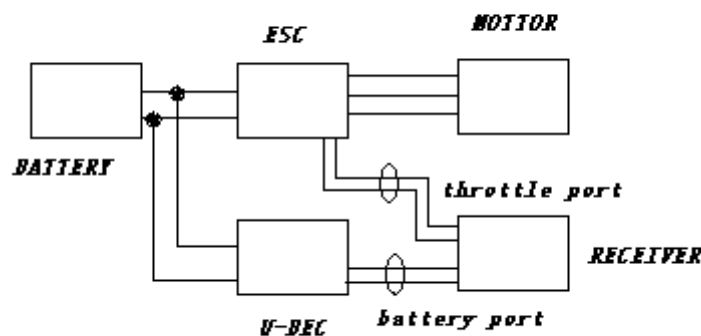

Brake -moving the transmitter throttle stick to the bottom position enables the prop brake.

Cutoff -The motor cutoff will occur when the input battery voltage drops below the programmed cutoff voltage (factory preset at 11.2V) for more than one half second. Once motor cutoff has occurred, moving the throttle to the braking position (full off) can re-arm the controller. This will allow restart of the motor at low throttle after cutoff has occurred. **WARNING:** Repeated restarting of the motor may drain the battery to a point where the radio receiver will stop operating, resulting in a loss of control of the model, and maybe less the use life of battery.

Loss of Transmitter Signal, or excessive radio noise cutoff -Motor cutoff will also occur if the signal from the transmitter is lost, or if the radio noise becomes excessive. After radio connection has been reestablished, moving the throttle to the braking position (full off) for four seconds can restart the motor.

Safe Power Up - The Safe Power up feature is a “finger saver”, designed to prevent the motor from starting accidentally on power up. To arm the controller, the transmitter stick must be held in the “Brake” position (all the way down) for at least four seconds. Until the controller is armed, it will not provide any power to the motor, regardless of where the throttle stick on your transmitter is positioned. Before flying your model, be sure to “blip” the throttle to ensure that the controller is armed.

LED – The LED is used for provides an indication that the controller has reached full throttle by lighting solid when full throttle is reached.

HM-60A

By HiModel RC Hobby

60Amp Brushless Sensorless Speed Controller

Warning! High power motor systems can be very dangerous! High currents can heat wires and batteries, causing fires and burning skin. Follow the wiring directions carefully! Model aircraft equipped with high power motors can kill. Always fly at a sanctioned field. Never fly over or near spectators. Even though this controller is equipped with a safety arming program, you should still use caution when connecting the main battery.

8.0 HM-60A Programming Features

Programming the **HM-60A** is as simple as answering a few questions. The **HM-60A** asks questions by “beep” a setting number, followed by the possible setting values. There are five settings that can be programmed in the **HM-60A**: 1) Cutoff voltage, 2) Brake Type, 3) Timing Advance and 4) Cutoff Type 5) Change the rotation of motor.

As the programmer, you must make one choice to the setting values as they are presented by the **HM-60A**. The setting values are “beep” out by the beeper.

When answering a question, you will need to move the transmitter stick to the full on throttle position keep it there for about 2 seconds. The **HM-60A** will use the number of “beep” to correspond your order. After then, the **HM-60A** will turn back to the programming mode and ask the next question.

You are not required to continue through all five programming options. You can choice what matter you want to change in the programming mode. The previous choice will keep when you leave the programming mode.

HM-60A

By HiModel RC Hobby
60Amp Brushless Sensorless Speed Controller

Warning! High power motor systems can be very dangerous! High currents can heat wires and batteries, causing fires and burning skin. Follow the wiring directions carefully! Model aircraft equipped with high power motors can kill. Always fly at a sanctioned field. Never fly over or near spectators. Even though this controller is equipped with a safety arming program, you should still use caution when connecting the main battery.

9.0 Entering Programming Mode

The **HM-60A** software is designed to make it difficult to *accidentally* enter programming mode, therefore it may seem like a long process to enter programming mode. This is to prevent entering programming mode while preparing to fly or while in flight. To enter programming mode, follow the steps below:

9.1 Verify Normal Operation

If this is the first time the **HM-60A** has been used, it is important to verify that the **HM-60A** operates normally with your transmitter otherwise programming may not function properly. Follow the instructions in section 6.0 Initialization Sequence (steps 1-4). Once you have verified that the **HM-60A** operates normally, proceed to 9.2 below. If the **HM-60A** does not operate properly, see section 11.0, Troubleshooting.

9.2 Enter Programming Mode By Transmitter Pole

9.2.1 Remove battery power from the **HM-60A**.

9.2.2 Move the transmitter stick to the top position (normally full “On”).

9.2.3 Reconnect battery power to the **HM-60A**.

9.2.4 After approximately 2 seconds, the **HM-60A** will emit a short tone, and the LED on the **HM-60A** should flash a short, that means power on . Then waiting for 5 seconds, you will hear four short “beep” and six long “beep”, and repetition. That means it have been in programming mode.

9.2.5 At the long “beep” appear, move your transmitter stick to the lowest position, you can make a choice as the table below show.

HM-60A “beep”	Operation	Setting	HM-60A Responses
Four short “beep”			
First long “beep”	Put stick to the lowest position	Cutoff voltage	One “beep”
Second long “beep”	Put stick to the lowest position	Brake Type	Two “beep”
Third long “beep”	Put stick to the lowest position	Timing Advance	Three “beep”
Fourth long “beep”	Put stick to the lowest position	Cutoff Type	Four “beep”
Fifth long “beep”	Put stick to the lowest position	Change rotation	Five “beep”
Sixth long “beep”	Put stick to the lowest position	Leave programming mode	Waiting 2 second, the “beep” one or two(section 8.0)

9.2.6 Proceed to Section 10.0 – Programming the **HM-60A**

HM-60ABy HiModel RC Hobby
60Amp Brushless Sensorless Speed Controller**Warning!** High power motor systems can be very dangerous! High currents can heat wires and batteries, causing fires and burning skin. Follow the wiring directions carefully! Model aircraft equipped with high power motors can kill. Always fly at a sanctioned field. Never fly over or near spectators. Even though this controller is equipped with a safety arming program, you should still use caution when connecting the main battery.**10.0. Programming the HM-60A:**

Important Note: When answering a question, you will need to move the transmitter stick to the yes (full “On” throttle) position and keep it there for about 2 seconds. When the **HM-60A** has accepted your answer, it will get responses. And return to the programming mode then ask the another question.

10.1 Programming Setting 1 –Cutoff Voltage

★Factory default settings are indicated by an asterisk in the option listings below.

HM-60A “beep”	Setting	Recommended for use with:	Operation	HM-60A Responses
one short “beep”				
First long “beep”	9.0V cutoff voltage	12 cell Ni-MH or 3 cell LiXX packs	Put stick to the top position	One “beep”
Second long “beep”	10.4V cutoff voltage	13 cell Ni-MH	Put stick to the top position	Two “beep”
Third long “beep”	★11.2V cutoff voltage	14 cell LiXX packs(per cell 2.8v)	Put stick to the top position	Three “beep”
Fourth long “beep”	12.0V cutoff voltage	4 cell LiXX packs	Put stick to the top position	Four “beep”
Fifth long “beep”	14.0V cutoff voltage	17 cell Ni-MH or 5 cell LiXX packs(per cell 2.8v)	Put stick to the top position	Five “beep”
Sixth long “beep”	15.0V cutoff voltage	5 cell LiXX packs	Put stick to the top position	Six “beep”
Seventh long “beep”	16.8V cutoff voltage	20 cell Ni-MH LiXX packs(per cell 2.8v)	Put stick to the top position	Seven “beep”
Eighth long “beep”	18.0V cutoff voltage	6 cell LiXX packs	Put stick to the top position	Eight “beep”

Note: Running the **HM-60A** asking the input voltage more than 10vdc.when it arrived the valve the power will off immediately.

10.2 Programming Setting 2 –Brake Type

HM-60A “beep”	Setting	Recommended for use with:	Operation	HM-60A Responses
two short “beep”				
First long “beep”	★No brake		Put stick to the top position	One “beep”
Second long “beep”	Brake		Put stick to the top position	Two “beep”

HM-60A

By HiModel RC Hobby
60Amp Brushless Sensorless Speed Controller

Warning! High power motor systems can be very dangerous! High currents can heat wires and batteries, causing fires and burning skin. Follow the wiring directions carefully! Model aircraft equipped with high power motors can kill. Always fly at a sanctioned field. Never fly over or near spectators. Even though this controller is equipped with a safety arming program, you should still use caution when connecting the main battery.

10.3 Programming Setting 3 – Electronic timing advance

HM-60A “beep”	Setting	Recommended for use with:	Operation	HM-60A Responses
three short “beep”				
First long “beep”	4° ~10°	12 or more pole motor	Put stick to the top position	One “beep”
Second long “beep”	★10° ~20°	6 or 8 pole motor	Put stick to the top position	Two “beep”
Third long “beep”	20° ~30°	2 or 4 pole motor	Put stick to the top position	Three “beep”

10.4 Programming Setting 4 – Cutoff Type

HM-60A “beep”	Setting	Recommended for use with:	Operation	HM-60A Responses
four short “beep”				
First long “beep”	cutoff		Put stick to the top position	One “beep”
Second long “beep”	★soft down		Put stick to the top position	Two “beep”

10.5 Programming Setting 5 – Change the rotation of the motor

HM-60A “beep”	Setting	Recommended for use with:	Operation	HM-60A Responses
five short “beep”				
First long “beep”	★			
Second long “beep”		Change rotation	Put stick to the top position	Two “beep”

10.6 Programming Setting 5 – Leave programming mode

Please see 9.2.5

HM-60A

By HiModel RC Hobby
60Amp Brushless Sensorless Speed Controller

Warning! High power motor systems can be very dangerous! High currents can heat wires and batteries, causing fires and burning skin. Follow the wiring directions carefully! Model aircraft equipped with high power motors can kill. Always fly at a sanctioned field. Never fly over or near spectators. Even though this controller is equipped with a safety arming program, you should still use caution when connecting the main battery.

11.0 Troubleshooting:

We are glad to get message and information from your experience.

12.0 Contact / Warranty Information:

Your **HM-60A** is warranted for *3 months* from date of purchase to be free from manufacturing and component defects. This warranty does not cover abuse, neglect, or damage due to incorrect wiring, over voltage, or overloading. If you have any questions, comments, or wish to return your **HM-60A** for warranty or non-warranty repair/replacement contact HIMODEL at:

HiModel RC Hobby

Address: No. 236-51 Liaoning Rd, Qingdao, CHINA 266012

Tel: (86-532) 83609069

Fax: (86-532) 83841601

Website: <http://www.HiModel.com>

Email: sales@himodel.com