

WFT09 RADIO CONTROL SYSTEM PCM1024

INSTRUCTION MANUAL S02



NOTICE

Read the instruction before operation!



www.wflysz.com

Thank you for purchasing WFLY product!

WFT09



SERVICE

1. Please come to our retail shops for services. Our retail shops will service you free in the first half year when you buy the radio.(apart from people damage)
2. WFLY retail shops will always take your radio service.

CATALOGUE

Contents-----	01
Transmitter front-----	03
Transmitter back-----	04
Receiver-----	05
Trainer function-----	06
Flying safety warnings-----	07
Features-----	08
BUTTONS-----	09
Editing mode and function introduction-----	10

HELICOPTER SYS SETTING

1. Model selecting-----	12
2. Model name-----	13
3. Model setting-----	14
4. ATL-----	15
5. Modulation setting-----	16
6. Swash select-----	17
7. Stick setting-----	18
8. Rest setting-----	19
9. Send data-----	20
10. Receive data-----	21
11. Contrast setting-----	22
14. Language-----	22
Curve setting-----	23

NORMAL SETTING

1. Monitor-----	24
2. Dual rate & Exponential-----	25
3. Servo reverse-----	26
4. End point-----	27

5. Sub trim-----	28
6. Swash param setting-----	29
7. Auxiliary channels setting-----	30
8. Throttle curve setting-----	31
9. Pitch curve setting-----	33
10. Revolution mixing-----	35
11. Trim step setting-----	36
12. Throttle cut setting-----	37
13. Fly model switch-----	38
14. Throttle holding setting-----	39
15. Fail safe-----	40
16. TIMER-----	41
18. Language-----	42

ADVANCED

(1). GYRO sens setting-----	44
(2). Throttle hovering setting-----	45
(3). Pitch hovering setting-----	46
(4). HI/LO PIT Setting-----	47
(5). Trim offset setting-----	48
(6). DELAY-----	49
(7). Governor mixing-----	50
(8). Swash and THR mixing-----	51
(9). Cuve setting-----	51
(10). PROG.NOR.MIX1-7-----	52
(11). PROG.CUR.MIX1-4-----	53
(12). Throttle needle mixing-----	54

AIRPLANE SYS SETTING

MODEL SELECTING-----	57
MODEL NAME-----	58
MODEL SETTING-----	59
ATL-----	60
AIL-2-----	61
MODULATION SETTING-----	62
STICK SETTING-----	63
REST SETTING-----	64
SEND DATA-----	65
RECEIVE DATA-----	66
CONTRAST SETTING-----	67
LANGUAGE-----	67

NORMAL SETTING

MONITOR-----	68
DUAL RATE & EXPONENTIAL SETTING-----	69
SERVO REVERSE-----	70
END POINT-----	71
SUB TRIM-----	72
AUXILIARY CHANNELS SETTING-----	73
THROTTLE CURVE SETTING-----	74
TRIM STEP SETTING-----	76
FLAPERON-----	77
FLAP TRIM-----	78
AIL-DIFF-----	79
ELEV-FLAP-----	80

THROTTLE CUT SETTING-----	81
IDLE DOWN-----	82
FAIL SAFE-----	83
TIMER-----	84
ADVANCED-----	85
LANGUAGE-----	86

ADVANCED

CURVE SETTING-----	87
PROG.NOR.MIX1-7-----	88
PROG.CUR.MIX1-4-----	89
AIR BRAKE-----	90
ELEVON-----	91
AILVATOR-----	92
V-TAIL-----	93
SNAP-ROLL-----	94
DELAY-----	95
THROTTLE NEEDLE MIXING-----	96
GYRO SENS SETTING-----	97

TO THE PILOT

Contents

Thank you for your attention and support to WFLY radio!

WFLY promises every WFT09 radio control system include the following contents:

1. WFT09 transmitter
2. WFTRF01 RF module
3. Battery holder for transmitter
4. Battery holder for receiver
5. Charger
6. Neckstrap
7. Trainer cable/Data transfer cable
8. Simulator cable
9. WFR09-P 8 channel dual conversion receiver PPM
10. WFR09-C 9 channel dual conversion receiver PCM
11. Switch harness
12. English instruction manual.

To thank WFLY customers, we provide two times free upgrade service.

The first version is for helicopter, the following two times upgrade will add airplane and glider function.

The buyer should take the transportation charge.

WFT09 Contents

1. Transmitter



2. RF module



3. Transmitter battery holder



4. Receiver batter holder



5 Charger



6. Neckstrap



7. Trainer cable/Data transfer cable



8. Simulator cable



9. PPM receiver



10. PCM receiver



11. Switch harness



TRANSMITTER

MODEL NO.: WFT09H
 MODULATION: FM(PPM) and PCM
 OUTPUT POWER: ≤700mW
 POWER SUPPLY: 1.2V x 8 (9.6V)
 CURRENT DRAIN: 200mA
 Band: 35, 36, 40, 41, 72MHz

TRANSMITTER FRONT

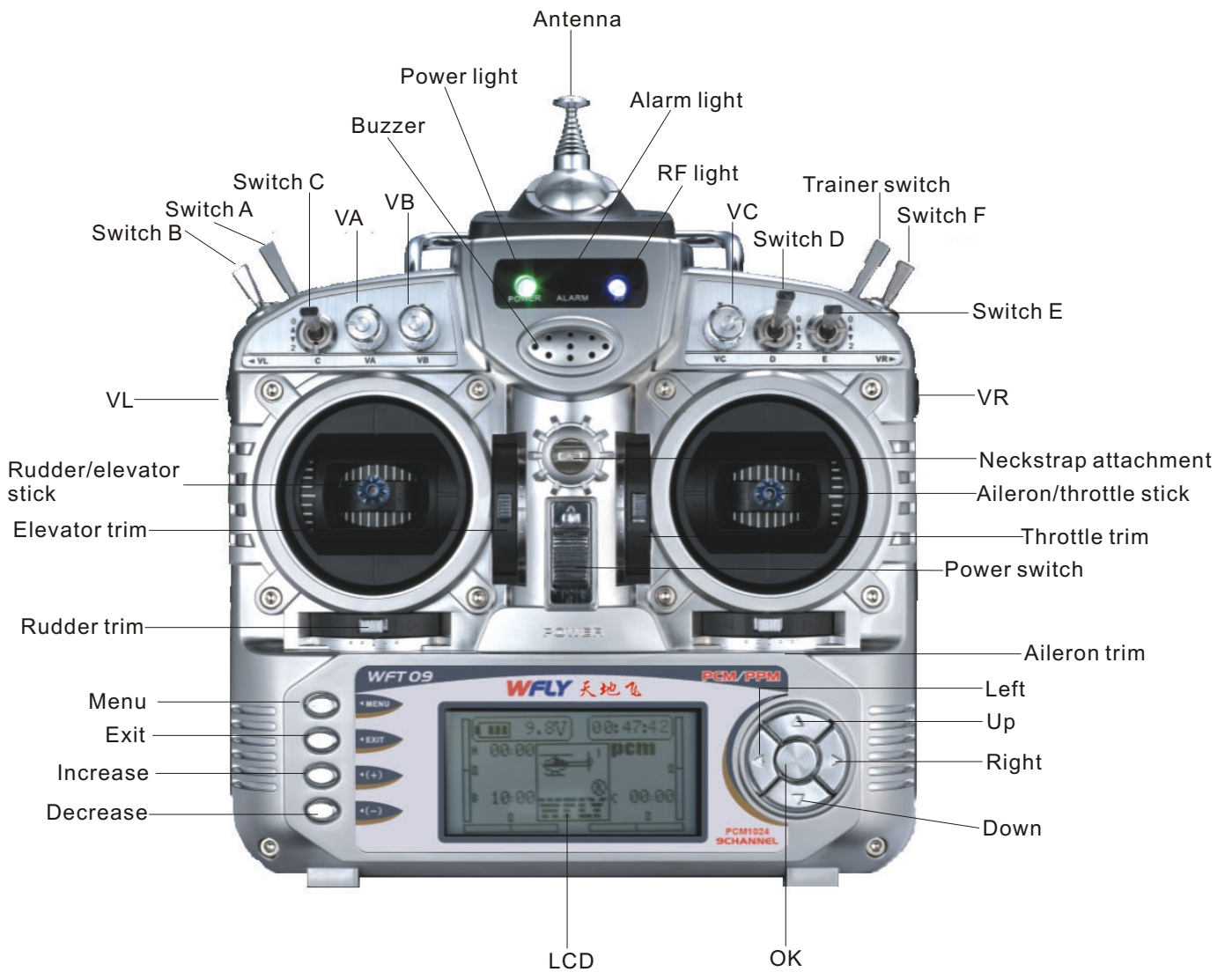

TRANSMITTER BACK



RECEIVER

MODEL NO.: WFR09

TYPE: 9 CH PCM/PPM, Dual conversion

POWER SUPPLY: 1.2V x 4 (4.8V)

CURRENT DRAIN: 9.5mA

WEIGHT: 19 g

DIMENSION: 44.88mm x27.90mm x16.39mm

BAND: 35, 36, 40, 41, 72MHz

WFR09-P 8 Channels Dual Conversion Receiver (PPM)

- 1. ALL: Aileron (Channel 1)-----
- 2. ELE: Elevator (Channel 2)-----
- 3. THR: Throttle (Channel 3)-----
- 4. RUD: Rudder (Channel 4)-----
- 5. GYR: Landing Gear/Gyro (Channel 5)-----
- 6. PIT: Pitch (Channel 6)-----
- 7. AUX1: Auxiliary channel 1 (Channel 7)-----
- 8. AUX2: Auxiliary channel 2 (Channel 8)-----
- 9. Power: Input +5V-----



(There are 9 rows needles, 3 needles in each row, from the top needle to the bottom, the 3 needles are PCM/PPM pulse, +5V and Ground.)

72MHz, pull up the switch to A, the receiver is compatible with WFLY and FUTABA series transmitters.

Pull down the switch to B, the receiver is compatible with JR series transmitters.

35MHz and 40MHz are compatible with WFLY, FUTABA and JR transmitters.

WFR09-C 9 Channels Dual Conversion Receiver (PCM)

The receiver is only used for WFT09 transmitter.

Make sure you set FAIL SAFE when using PCM.

- 1. ALL: Aileron (Channel 1)-----
- 2. ELE: Elevator (Channel 2)-----
- 3. THR: Throttle (Channel 3)-----
- 4. RUD: Rudder (Channel 4)-----
- 5. GYR: Landing Gear/Gyro (Channel 5)-----
- 6. PIT: Pitch (Channel 6)-----
- 7. AUX1: Auxiliary channel 1 (Channel 7)-----
- 8. AUX2: Auxiliary channel 2 (Channel 8)-----
- 9. Power: Input +5V-----



(There are 9 rows needles, 3 needles in each row, from the top needle to the bottom, the 3 needles are PCM/PPM pulse, +5V and Ground.)

Indicator light

- 1. Usually, it's Bit Error Rate indicator. The light becomes brighter when the rate is bigger.
- 2. The light glitters once per second when the voltage is low.
- 3. The light glitters once per 0.4 second when receiving data(Fail safe) or big Bit Error Rate occurs.



Trainer function

Two WFT09 transmitters can transfer data and realize trainer function.

Setting Method :

- 1).Data transfer function: use Trainer cable/Data transfer cable to connect two WFT09 transmitter.
Select “Send data/receive data” in SYS setting to transfer the data.
- 2).Trainer function: use Trainer cable/Data transfer cable to connect two WFT09 transmitters.
Insert RF module to the trainer transmitter, student transmitter doesn't insert the RF module.
Pull Trainer switch for student transmitter operating. If any wrong operation occurs, trainer pushes trainer switch and student transmitter stops sending signal, trainer transmitter controls the aircraft.

FLYING SAFETY WARNINGS

Special Symbol Instruction

To use the product safely, please pay attention to the instruction as follows.

Please pay special attention to the symbol as follows:

- ⚠ **Dangers:** If you use it without proper operation, it is possible to hurt you seriously or may even cause death.
- ⚠ **Warnings:** If you use it without proper operation, it may make you or others to hurt badly or may even cause death, and it may cause slight hurt or damage to things.
- ⚠ **Notices:** If you use it without proper operation, it may cause you to hurt slightly or damage things , but it won't hurt you seriously normally.
- ⚠ **Notices:** Children under 14 must be accompanied and instructed by adults!
- ⚠ **Notices:** Turn on the transmitter first, then the receiver. When turning off the system, turn off the receiver first, then the transmitter.

Flying Notice(warning) ⓧ Forbiddance! Ⓢ Obligation! ⚠ Warning!

Same frequencies can't fly at the same time.



Same frequencies used synchronously will cause the plane to crash or to damage even the modulation ways of AM, FM, PCM are not the same, when the frequencies are identical, it will cause the plane to prang or to damage.



Do not fly at night , in rain day ,or in strong wind, which will damage the device or plane. This device is not water-proof.



The antenna should be fully pulled out when using it or the signal will be weakened and the control range will reduce, which may cause the crash.

Checking



Please check every servo works properly and eliminate any disturbing signals before you play it. (If the radio bounces after turning off the power, there may be some disturbances, in this case, please change your channel by exchange crystals)

FEATURES

Computerized transmitter.

132 x 64 FSTN LCD, easy operating buttons.

Metal slab shell.

Adjustable antenna basement.

Tightness and length of the control stick can be adjusted freely.

Excellent touch of the stick movement.

Full digital trim.

Independent RF module for easy band exchange.

Trainer function.

3 independence timer, all can be set to count down or increment.

PCM and PPM modulation supported.

Multi mixing function.

All curves have eleven fully position adjustable point.

User defined switch and knob.

Model parameter can be exchange between transmitter..

10-model memory.

WFT09 transmitter is compatible with FUTABA and JR (PPM) receiver.

Dual conversion receiver(PPM) is compatible with FUTABA and JR transmitter.

Buttons



MENU

Menu button brings you to the function list of the transmitter.

EXIT

Exit button is to back the previous menu or exit edit.

+

This button is to increase the value. If you press it for a while, the increasing speed will be faster.

-

This button is to decrease the value. If you press it for a while, the decreasing speed will be faster.

Cursor buttons

Move the cursor.

OK

The button in the middle of the direction buttons is the OK button.

The function is as follows:

To enter the function list.

To enter the edit function.

To back the default for long time press.

HELICOPTER

Press Menu and turn on the transmitter to enter SYS SETTING.
Select MODEL SETTING, press OK button to select the model type.
Restart the transmitter after setting.

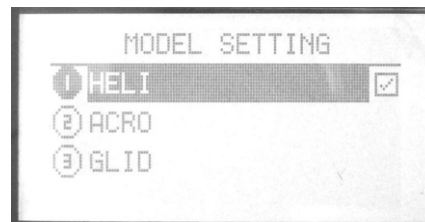
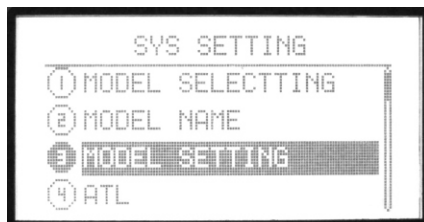

Editing mode and function introduction

1. Opening Screen

Turn on the power switch, the LCD displays as follows.

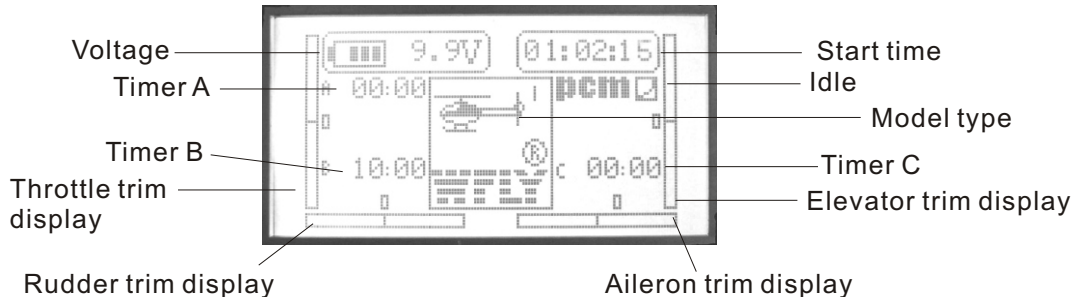

The opening screen displays the voltage, timer, model, aileron, throttle, elevator and rudder state.

Note: Press EXIT you can see the model name.

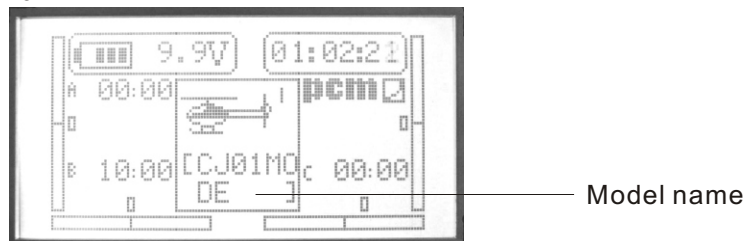

2. Menu Screen

There are “System setting”, “SYS setting”, “More setting”.

A. System setting

Turn on the transmitter, press the menu button, the LCD displays as follows.

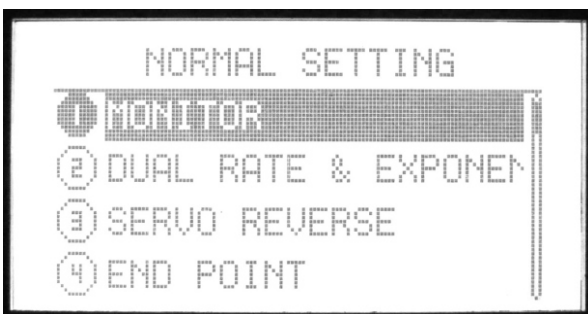

Setting method:

- Use direction button to select the editing part, use up/down buttons to select function item. Left/right direction button to turn page.
- Press OK button to enter submenu. The submenu function is in the next chapter.
- Press EXIT button to back previous menu and the data is set automatically.

- MONITOR
- DUAL RATE & EXPONENTIAL SETTING
- SERVO REVERSE
- END POINT
- SUB TRIM
- SWASH PARAM SETTING
- AUXILIARY CHANNELS
- THROTTLE CURVE SETTING
- PITCH CURVE SETTING
- REVOLUTION MIXING
- TRIM STEP SETTING
- THROTTLE CUT SETTING
- FLY MODEL SWITCH
- THROTTLE HOLDING SETTING
- FAIL SAFE
- TIMER
- MORE SETTING
- LANGUAGE

B. SYS SETTING

Press Menu and turn on the power switch, the LCD displays as follows.

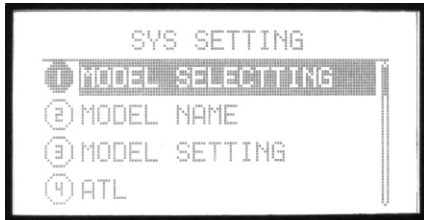

1. MODEL SELECTTING
2. MODEL NAME
3. MODEL SETTING
4. ATL
5. MODULATION SETTING
6. SWASH SELECT
7. STICK SETTING
8. REST SETTING
9. SEND DATA
10. RECEIVE DATA
11. CONTRAST SETTING
12. ENGINEER MODEL
13. ABOUT
14. LANGUAGE

Setting method:

1. Use direction button to select the editing part, use up/down buttons to select function item. Left/right direction button to turn page.

2. Press OK button to enter submenu. The submenu function is in the next chapter.

3. Press EXIT button to back previous menu and the data is set automatically.

C. ADVANCED

1. Enter "NORMAL SETTING", use right direction button to turn page, select "ADVANCED".

Press OK button to enter.



Setting method:

1. Use direction button to select the editing part, use up/down buttons to select function item. Left/right direction button to turn page.

2. Press OK button to enter submenu. The submenu function is in the next chapter.

3. Press EXIT button to back previous menu and the data is set automatically.

SYS SETTING

1. Model selectting



There are 10 helicopter models. You can select any one to set.

Setting Method:

Press Menu and turn on the transmitter to enter "SYS SETTING"
Use up/down button to select "**Model selectting**", OK button is to enter editing.

Steps:

1. Use up/down direction button to select the model.
2. Press OK button to select.
3. Press EXIT after setting.

2. Model name

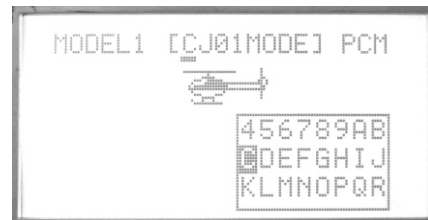
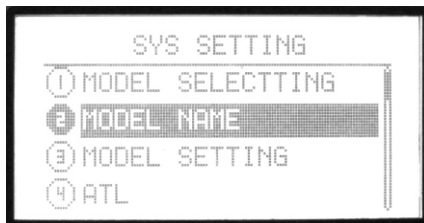

This function is to make new names by users.

Setting Method:

Press Menu and turn on the transmitter to enter “SYS SETTING”
Use up/down button to select “**Model name**”, OK button is to enter editing.

Steps:

1. You can edit the underlined letter.
2. Press OK button to choose the word you like.
3. Press EXIT after setting.

3. Model setting

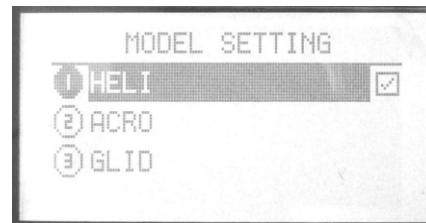
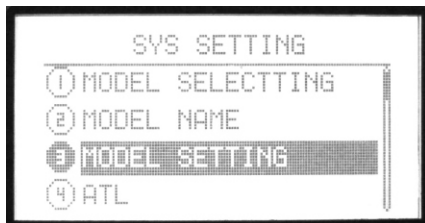

You can select the model type. There are three type: HELI, ACRO, GLID.

Setting Method:

Press Menu and turn on the transmitter to enter "SYS SETTING"
Use up/down button to select "**Model setting**", OK button is to enter editing.

Steps:

1. Use up/down direction button to select the model type.
2. Press OK button to confirm.
3. Press EXIT after setting.

4. ATL

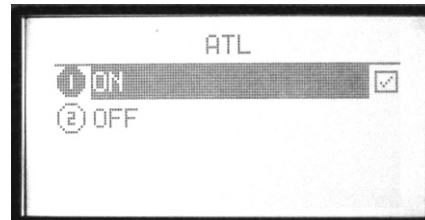
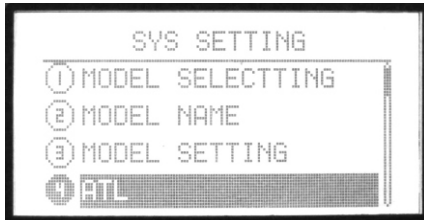

Adjustable travel limit (ATL) makes throttle trim effective only at low throttle, disabling the trim at high throttle. This prevents pushrod jamming due to idling trim changes. This function defaults to ON. If you are not using channel 3 for throttle, you may want trim operation the same as on all other channels. To do so, set ATL to OFF.

Setting Method:

Press Menu and turn on the transmitter to enter "SYS SETTING". Use up/down button to select "**ATL**", OK button is to enter editing.

Steps:

1. Use direction buttons to select the editing part.
2. Press +/- button to set ATL function.
3. Press EXIT after setting.

5.Modulation setting



Because of the different receiver modulation PPM/PCM, the transmitter should be accordance with the receiver modulation.

Setting Method:

Press Menu and turn on the transmitter to enter "SYS SETTING"
Use up/down button to select "**Modulation setting**", OK button is to enter editing.

Steps:

1. Use direction buttons to select the editing part.
2. Press OK button to confirm. Restart the transmitter and it works.

6.Swash select

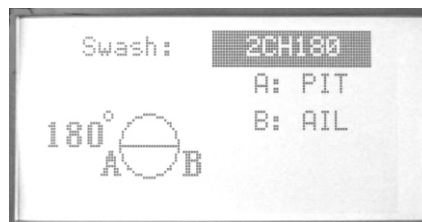
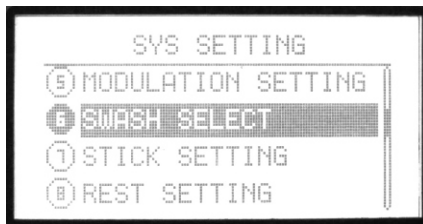

There are 6 kinds of swash. You can select the swash you preferred. If you use 120 degree CCPM helicopter, the servos will realize mix function automatically. Please select the swash according to your helicopter swash type.

- 1 servo (not CCPM, normal helicopter)
- 2 servos (180 degree)
- 3 servos (90, 120, 140 degree)
- 4 servos (90 degree)

Setting Method:

Press Menu and turn on the transmitter to enter "SYS SETTING"
Use up/down button to select "**Swash select**", OK button is to enter editing.

Steps:

1. Use direction button to select the editing part.
2. Press +/- button to choose the swash type.
3. Press EXIT after setting.

7. Stick setting

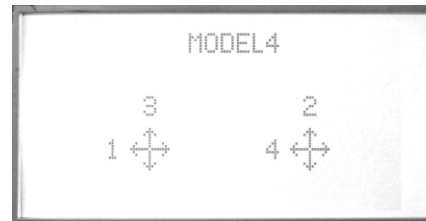
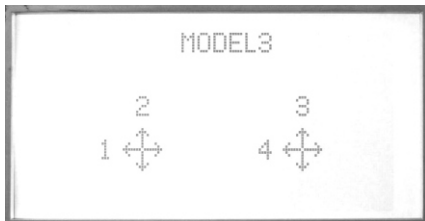
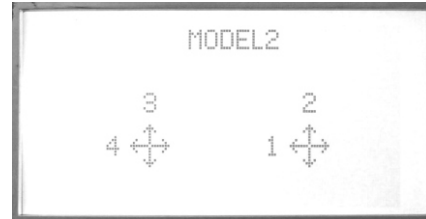
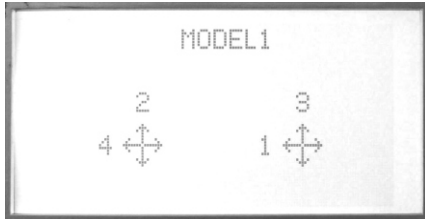

There are 4 kinds of model, you can use up/down direction button to select the model you preferred.

- 1-aileron
- 2-elevator
- 3-throttle
- 4-rudder

Setting Method:

Press Menu and turn on the transmitter to enter "SYS SETTING"
Use up/down button to select "**Stick setting**", OK button is to enter editing.

Steps:

1. Use direction button to select the editing part.
2. Press up/down button to choose Stick mode.
3. Press EXIT after setting.

8. Rest setting



This function is to back default.

Setting Method:

Press Menu and turn on the transmitter to enter "SYS SETTING"
Use up/down button to select "**Rest setting**", OK button is to enter editing.

Steps:

1. Use direction button to select the editing part.
2. Press +/- button to back default.
3. Press EXIT after setting.

9. Send data

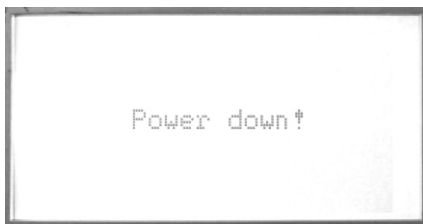
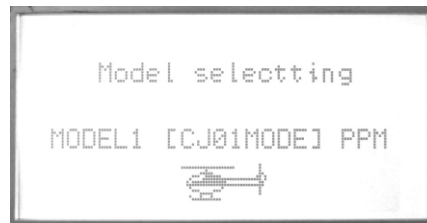
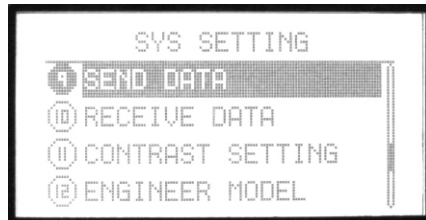

Two transmitters (WFT09) can copy data by a trainer cable/data transfer cable. This function together with the next function "Receive data" can realize the data copy.

Setting Method:

Press Menu and turn on the transmitter to enter "SYS SETTING". Use up/down button to select "**Send data**", OK button is to enter editing.

Steps:

1. Select the model data you want to send out.
2. Press OK to send.

10.Receive data



Two transmitters (WFT09) can copy data by a trainer cable/data transfer cable. This function together with the previous function “Send data” can realize the data copy.

Setting Method:

Press Menu and turn on the transmitter to enter “SYS SETTING” Use up/down button to select “**Receive data**”, OK button is to enter editing.

Steps:

1. Press OK to receive data.
2. Restart the transmitter after receiving the data and it works.

11. Contrast setting

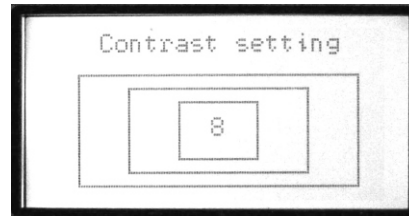

This function is to adjust the LCD brightness by increasing or decreasing the contrast value.

Setting Method:

Press Menu and turn on the transmitter to enter “SYS SETTING”
Use up/down button to select “**Receive data**”, OK button is to enter editing.

Steps:

1. Use +/- button to increase or decrease the value.
2. Press OK button for a while is to back default.
3. Press EXIT after setting.

14. Language

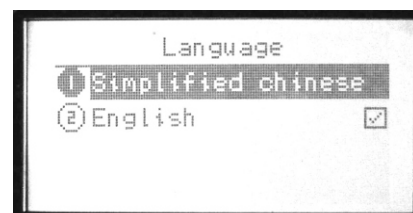

This function is to select the language, Simplified Chinese and English can be selected.

Curve setting

1. Setting introduction

Curve setting is one of the functions of WFT09. We will make detail description here. You can refer to this detail description for the other functions which relates to the curve setting.

There are two kinds of curve setting mode: normal setting and advanced setting.

Normal setting: 7 points curve setting. You can set the curve by set the 7 points value.

Advanced setting: you can add or delete the curve point.

Advanced curve can be added at most 11 points, at least 2 points. You can not only set the value of each point, but also the position of each point.

2. Setting method

Turn on the transmitter, press menu, find "More setting", select "curve setting".

There are two modes: normal, advanced.

Normal curve setting: 7 points curve setting. You can edit the curve point in the left pane.

1. Use left/right direction button to select the editing point. The curve point is marked by a dashed line.

2. Use +/- button to set the value. Press OK button for a while can back to default. You can set the 7 points.

3. Press EXIT after setting.

Advanced curve setting: User can add or delete the curve point.

D/R curve has 11 points and every point can be set. Press +/- button for seconds can add/delete curve point. It can at most add to 11 points and delete to 2 points.

When selecting one point, use left/right button to choose the point you want to edit, press OK button to enter editing.

Active the cursor, use up/down direction button to set the left value in the pane, use left/right direction button to set the right value in the pane.

The black cursor is the editing part, which is marked by a dashed line.

NORMAL SETTING(helicopter)

1. MONITOR

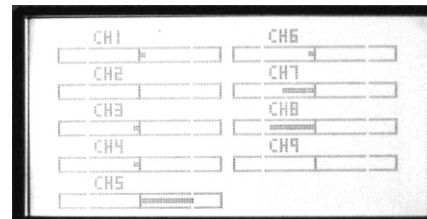
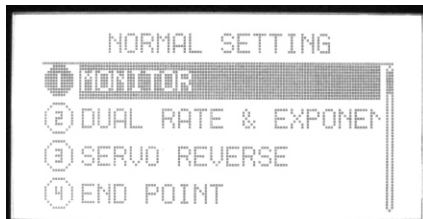

Monitor shows the servos' movement situation.

In PCM, this function is to describe the 9 channels output.

In PPM, this function is to describe the first 7 channels output.

Setting Method:

Press menu button, enter system setting, the first function is the monitor.

2. DUAL RATE & EXPONENTIAL SETTING

(1). AIL

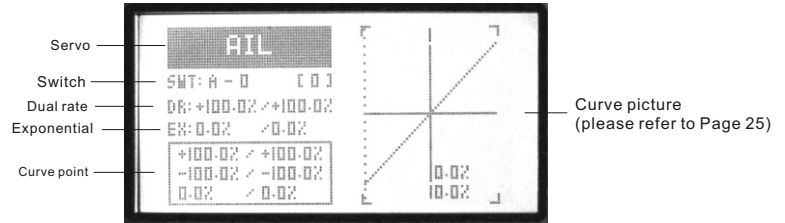

(2). ELE

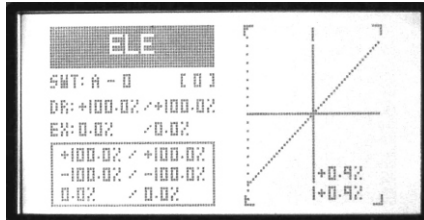

(3). RUD

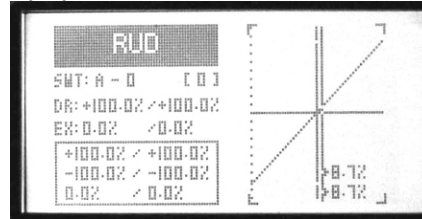

Dual rate is to adjust aileron, elevator and rudder travel range. The range is between 0%-120%.

Exponential setting is to adjust aileron, elevator and rudder sensitivity when the sticks are around the middle. The range is between -100% to +100%.

Setting Method:

1. Select channel

Aileron, elevator and rudder are selectable. Press +/- buttons to select channel, OK button to finish setting.

2. Set the switch and its position(0,1,2)

Press direction button to select "SWT", edit it. +/- buttons can select function switch(A-F).

After selecting the function switch, press right direction button to enter the switch position setting, use +/- buttons to set.

3. Set dual rate

Press direction button to select "D/R", edit it. Edit one or two parameter.

+/- buttons can increase or decrease the value.

Press the OK button is to back default.

4. Set exponential

Press direction button to select "EX". Exponential can adjust aileron, throttle and rudder sensitivity as the stick at the middle.

5. Set curve point (normal/advanced)

The box under "EX" shows the curve points.

Select "Curve setting" in More setting function list.

Please refer to Page 25 for detail curve setting.

6. Press EXIT after all the values are finished setting.

3. SERVO REVERSE

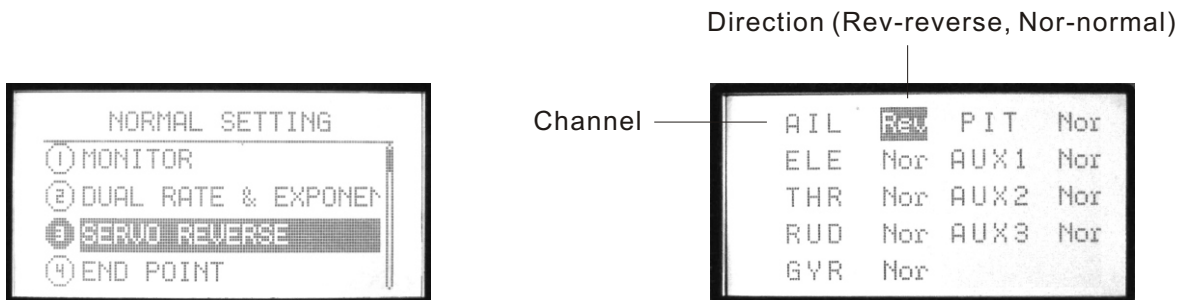

This function is to change the direction of the servos movement.

Setting Method:

Use up/down button to select **Servo reverse**, OK button is to enter editing.

Steps:

1. Use direction buttons to select editing part.
2. Use +/- button or OK button to switch the servo movement direction.
3. Press EXIT after setting.

4. END POINT

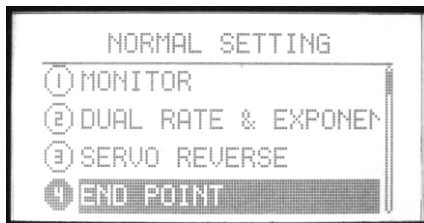

Channel	Side	Value		Value
AIL	L	100.0%	R	100.0%
ELE	D	100.0%	U	100.0%
THR	L	100.0%	H	100.0%
RUD	L	100.0%	R	100.0%
GYR	L	100.0%	H	100.0%

It is to adjust the end of individual servo's travel. The range is from 0% to 120%.

Setting Method:

Use up or down button to select **End point**, OK button is to enter editing.

Steps:

1. Use direction buttons to select editing part.
2. Use +/- button or OK button to set the travel value. Press OK for a while backs to default.
3. Press EXIT after setting.

5. SUB TRIM

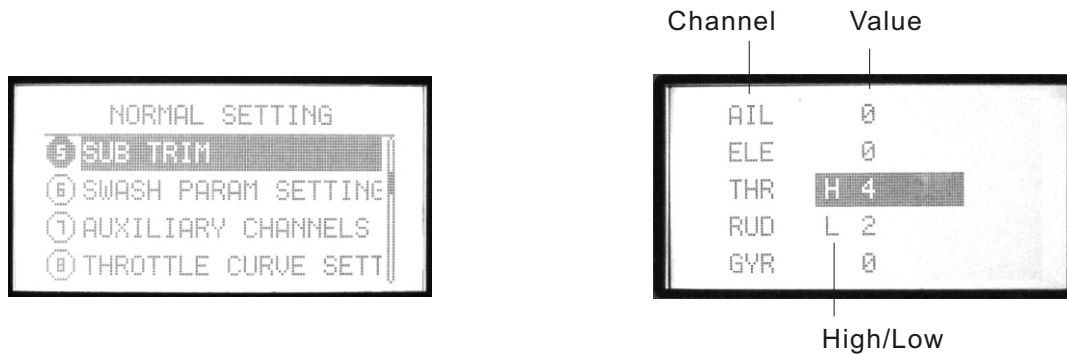

Sub trim makes small changes or corrections to the neutral position of each servo. Range is -120 to +120, default setting is 0.

We recommend that you center the digital trims before making Sub trim changes, and that you try to keep all of the Sub trim values as small as possible. Otherwise, when the Sub trims are large values, the servo's range of travel is restricted on one side.

Setting Method:

Use up or down button to select Sub trim, OK button is to enter editing.

Steps:

1. Use direction buttons to select editing part.
2. Use +/- button or OK button to set the trim value. Press OK for a while backs to default.
3. Press EXIT after setting.

6. SWASH PARAM SETTING

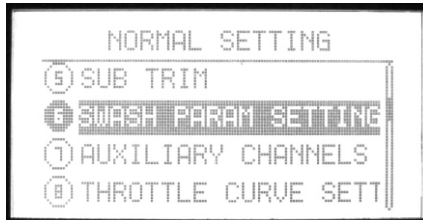

Effecton
direction Value

This function is to adjust the aileron, elevators and pitch travel range of swash mixing mode.

Setting Method:

Use up or down button to select **Swash param setting**, OK button is to enter editing.

Steps:

1. Use direction buttons to select editing part.
2. Use +/- button to set the travel. Press OK button for a while is to back default(60%).
3. Press EXIT after setting.

7. AUXILIARY CHANNELS SETTING

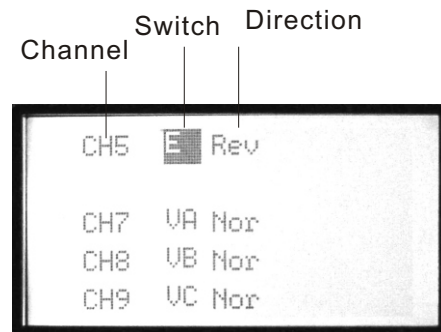
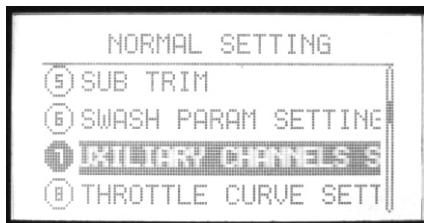

This function is for channel 5 to channel 9 function setting.

Setting Method:

Use up or down button to select Swash param setting, OK button is to enter editing.

Steps:

1. Use direction buttons to select editing part.
2. Use +/- button to set the switches or knobs. The switches can be set from A to F, the knobs can be set as VA, VB, VC, VL, VR or none(-).
3. Use left or right direction button to set normal or reverse direction of every channel.
4. Press EXIT after setting.

8. THROTTLE CURVE SETTING

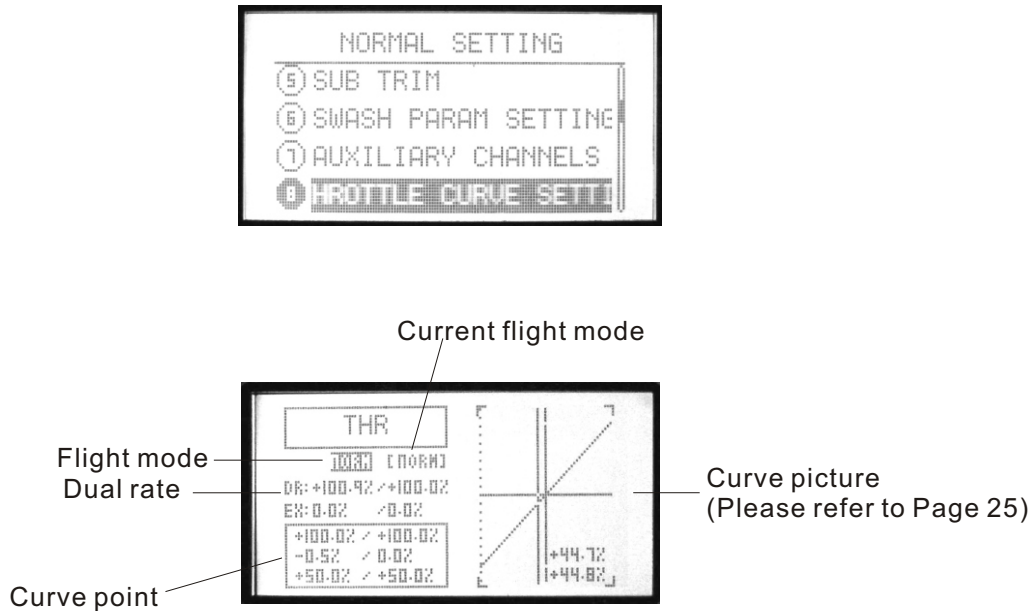

Throttle curve, together with the throttle stick, can be adjusted properly to maximize engine performance at a particular pitch setting.

There are two kinds of curve setting, normal (7 points curve), advanced (2-11 points curve), the range is between 0%-120%. The transmitter can set the following curves: NORM, IDLE1, IDLE2, IDLE3.

Normal curve is based on hovering, to maximize engine performance at a particular pitch setting.

Idle curve is for engine proper work in a 3D flight, with a good match between throttle and pitch.

Setting Method:

Use up/down button to select **Throttle curve setting**, OK button is to enter editing.

Steps:

1. Flight(NORM IDLE1 IDLE2 IDLE3)
Use direction buttons to select editing part. Use +/- button to select one curve.
2. Set Dual rate
Use direction button to select "D/R" and edit (one or two values can be set separately or together). Press +/- button for seconds can increase or delete the value. Press OK button for seconds is to back default(60%).
3. Curve point setting(Normal/Advanced)
The below pane shows the points curve.
Select "Curve setting" in "SYS setting", choose the curve.
For detail curve setting method please refer to Page 25.
4. Press EXIT after setting.

9. PITCH CURVE SETTING

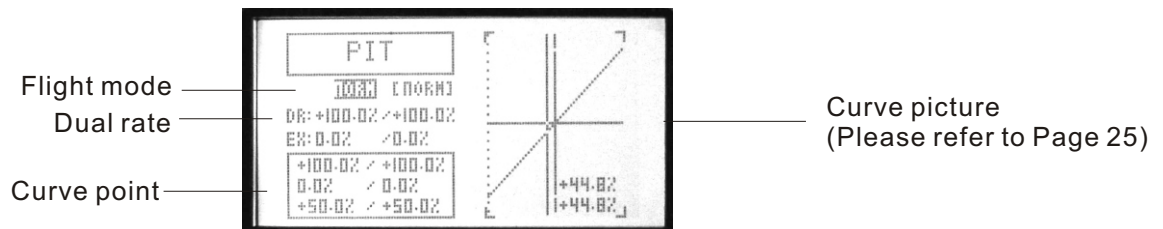
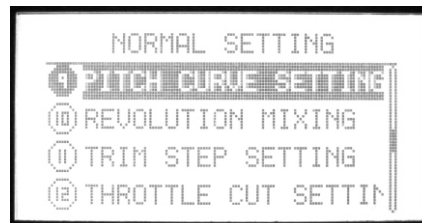

Pitch curve, together with the throttle stick, can be adjusted properly to maximize engine performance at a particular pitch setting.

There are two kinds of curve setting, normal (7 points curve), advanced (2-11 points curve), the range is between 0%-120%. The transmitter can set the following curves: NORM, IDLE1, IDLE2, IDLE3.

Normal curve is based on hovering, to maximize engine performance at a particular pitch setting.

Idle curve is for engine proper work in a 3D flight, with a good match between throttle and pitch.

Setting Method:

Use up/down button to select **PITCH CURVE SETTING**, OK button is to enter editing.

Steps:**1. Flight(NORM IDLE1 IDLE2 IDLE3)**

Use direction buttons to select editing part. Use +/- button to select one curve.

2. Set Dual rate

Use direction button to select "D/R" and edit (one or two values can be set separately or together). Press +/- button for seconds can increase or delete the value. Press OK button for seconds is to back default(60%).

3. Curve point setting(Normal/Advanced)

The below pane shows the points curve.

Select "Curve setting" in "SYS setting", choose the curve.
For detail curve setting method please refer to Page 25.

4. Press EXIT after setting.

10. REVOLUTION MIXING

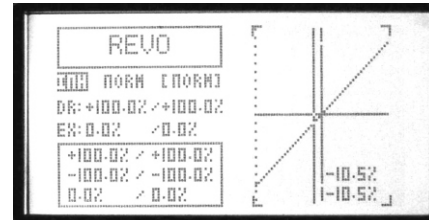

This curve mix adds opposite rudder input to counteract the changes in torque when the speed and collective pitch of the blades is changed.

Setting Method:

Use up/down button to select **Revolution mixing**, OK button is to enter editing.

Steps:

1. Flight(NORM IDLE1 IDLE2 IDLE3)
Use direction buttons to select editing part. Use +/- button to select one curve.
2. Set Dual rate
Use direction button to select "D/R" and edit (one or two values can be set separately or together). Press +/- button for seconds can increase or delete the value. Press OKbutton for seconds is to back default(60%).
3. Curve point setting(Normal/Advanced)
The below pane shows the points curve.
Select "Curve setting" in "SYS setting", choose the curve.
For detail curve setting method please refer to Page 25.
4. Press EXIT after setting.

11. TRIM STEP SETTING

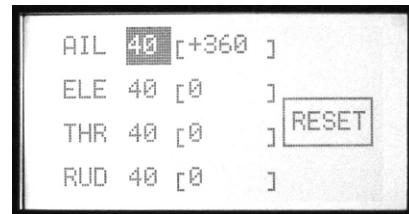

This function is to change the rate at which the trim moves when the TRIM LEVER is activated. The range is from 0 to 250. Generally larger trim steps are for models with larger control throws or for first flights to ensure sufficient trim to properly correct the model. Smaller trim steps are later used to allow very fine adjustments in flight.

Setting Method:

Use up/down button to select **Trim step setting**, OK button is to enter editing.

Steps:

1. Use direction buttons to select editing part.
2. Use +/- button to adjust the size of the step,
3. Repeat as desired for other channels.
3. Press EXIT after setting.

12. THROTTLE CUT SETTING

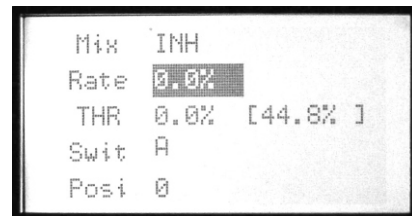

This function is to shut off the engine at the end of a flight. The engine can be stopped with one touch of any switch, eliminating the need to move the trim to kill the engine and then readjust prior to each flight. The helicopter THR CUT includes an ON/OFF throttle position (normally a little above idle). You must move the THROTTLE STICK back below the set point before the THR-CUT function can be reset, to avoid sudden engine acceleration.

Setting Method:

Use up/down button to select **Throttle cut setting**, OK button is to enter editing.

Steps:

1. Use direction buttons to select editing part.
2. Use +/- button to turn on/off throttle cut function.
3. Use +/- button to set the throttle rate and trim (range is between +45% to -45%).
4. Use +/- button to set the position.
5. Press EXIT after setting.

13. FLY MODEL SWITCH

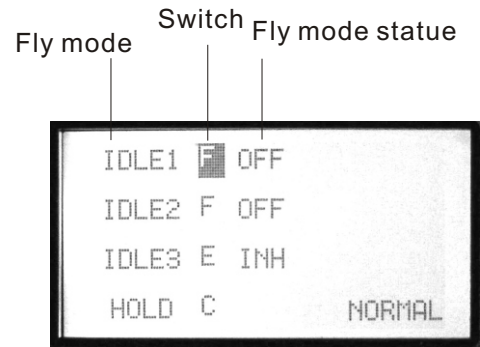
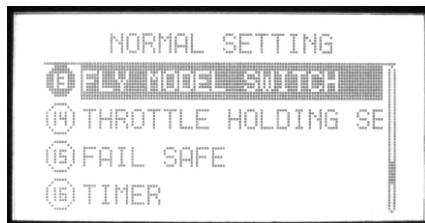

This function is to select the flight mode.

Setting Method:

Use up/down button to select **Fly model switch**, OK button is to enter editing.

Steps:

1. Use direction buttons to select editing part.
2. Use +/- button to set every fly model.
3. Use +/- button to set fly model ON/OFF position.
4. Press EXIT after setting.

14. THROTTLE HOLDING SETTING

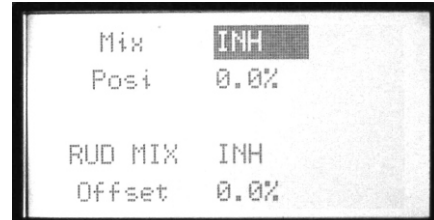
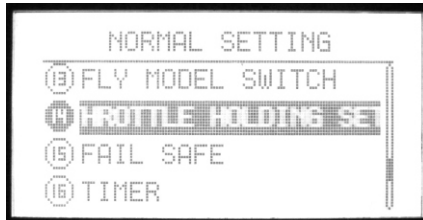

This function can make the throttle servo operating at a low speed position at the end of a flight. The range is between -75% and +75%.

User can set the mix function with rudder under the throttle holding state and the mix rate (offset).

This function switch can be found in “**Fly model switch**”.

Setting Method:

Use up/down button to select **Throttle holding setting**, OK button is to enter editing.

Steps:

1. Use direction buttons to select editing part.
2. Use +/- button to active or inhibit the mix function.
3. Use +/- button to set the throttle holding position.
4. Use +/- button to active or inhibit the rudder mix.
5. Use +/- button to set the mix rate (offset). Press OK button for seconds can back to default.
6. Press EXIT after setting.

15. FAIL SAFE

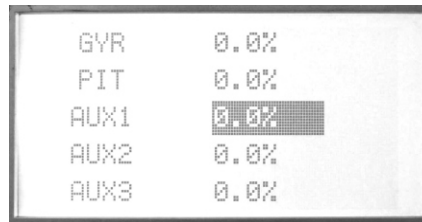
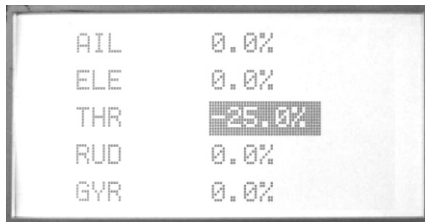

This function is to set responses in case of loss of signal or low RX battery.

Setting Method:

Use up/down button to select **Fail safe**, OK button is to enter editing.

Steps:

1. Use direction buttons to select editing part.
2. Use +/- button to select "hold" or "0.0%"
3. Press OK button to confirm the current parameter.
4. Press EXIT after setting.

16. TIMER

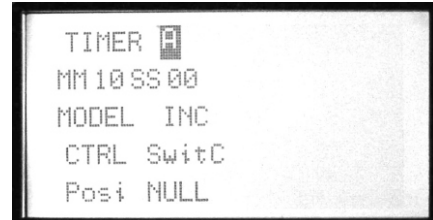

The flight time of every helicopter is different according to the different tank of fuel, engine, ESC, etc. Timer function can alarm you to land before the fuel lacks.

The transmitter can set 3 timers (A, B, C). The longest time can be set as MM99SS59. The countdown timer can alarm user before 10 minutes. The alarm will become 2S/1S from 1S/1S in the last 10 seconds. When the countdown timer is 0, the time will add up.

The timer can be seen in the opening screen. Any switch can be set to control the begin and stop of the time.

Setting Method:

Use up/down button to select **TIMER**, OK button is to enter editing.

Steps:

1. Use direction buttons to select editing part.
2. Set timer. WFT09 can set 3 timers (A, B, C).
3. Use +/- button to set MM..SS... Press OK button for seconds can back to default.
4. Use +/- button to set model.
5. Use +/- button to set control(CTRL).
6. Use +/- button to set the position which can active this function.
7. Press EXIT after setting.

18. LANGUAGE

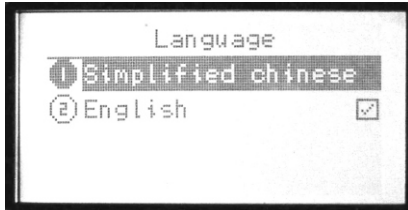

This function is to select the language, Simplified Chinese and English can be selected.

17. ADVANCED



To realize an idea fly, there are 17 advanced function in More setting.

Setting Method:

Use up/down button to select **ADVANCED**, OK button is to enter editing. +/- button can turn page.
About each advanced functions please read the following pages.

ADVANCED FUNCTION INTRODUCTION

(1). GYRO SENS SETTING

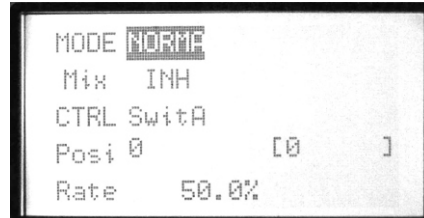

User can adjust the gyro sensitivity by transmitter, AVCS gyro (GY) and normal gyro (STD).

Gyro sensitivity switch plug should plug in the fifth channel of receiver. The auxiliary channel CH 5 won't have any function now. User can set sensitivity switch from switch A to F, and also fly model (NORM, IDLE1,2,3).

Setting Method:

Use up/down button to select **GYRO sens setting**, OK button is to enter editing.

Steps:

1. Use direction buttons to select editing part.
2. Use +/- button to set fly model at "MODE".
3. Use +/- button to active or inhibit "Mix". Press OK button for seconds can back default.
4. Use +/- button to set control switch at "CTRL".
5. Use +/- button to set the switch position when the function is active.
6. Use +/- button to set the "Rate". Press OK button for seconds can back default.
7. Press EXIT after setting.

(2). THROTTLE HOVERING SETTING

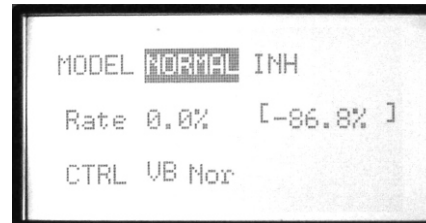

Throttle hovering setting is fine-tuning adjustments for the throttle, affecting performance only around the center point and only in the normal condition. This function can set knob VA/VB/VC to control, turn right the rotor speed becomes faster, turn left the rotor speed becomes slower.

Rotor speed changes caused by temperature, humidity, altitude or other changes in flying conditions are easily accommodated.

Setting Method:

Use up/down button to select **Throttle hovering setting**, OK button is to enter editing.

Steps:

1. Use direction buttons to select editing part.
2. Use +/- button to select "MODEL".
Use +/- button to active or inhibit this function.
3. Use +/- button to set "Rate". Press OK button for seconds can back default.
4. Use +/- button to set control switch.
5. Press EXIT after setting.

(3). PITCH HOVERING SETTING

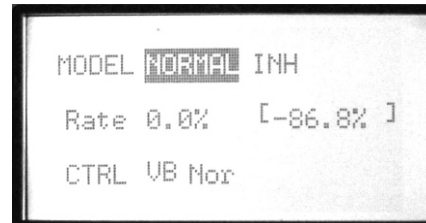

Pitch hovering setting is fine-tuning adjustments for the pitch, affecting performance only around the center point and only in the normal condition.

This function can set knob VA/VB/VC/VR/VL to control, turn right the rotor speed becomes faster, turn left the rotor speed becomes slower.

Rotor speed changes caused by temperature, humidity, altitude or other changes in flying conditions are easily accommodated.

Setting Method:

Use up/down button to select **Pitch hovering setting**, OK button is to enter editing.

Steps:

1. Use direction buttons to select editing part.
2. Use +/- button to select "MODEL".
Use +/- button to active or inhibit this function.
3. Use +/- button to set "Rate". Press OK button for seconds can back default.
4. Use +/- button to set control switch.
5. Press EXIT after setting.

(4). HI/LO PIT SETTING

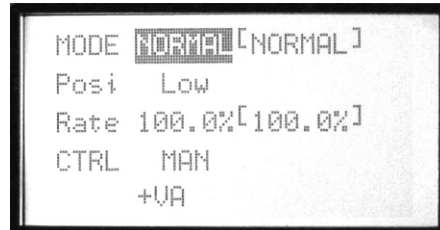

This function is to set the high and low pitch position at different flying modes.

This function can set knob VA/VB/VC/VR/VL to control or controlled by user "CTRL MAN".

IF "CTRL MAN", the pitch is set by "Rate", the range is between 60%-100%.

Setting Method:

Use up/down button to select **HI/LO PIT setting**, OK button is to enter editing.

Steps:

1. Use direction buttons to select editing part.
2. Use +/- button to select "MODEL".
Use +/- button to active or inhibit this function.
3. Use +/- button to set the "Pos", low or high.
4. Use +/- button to set "Rate". Press OK button for seconds can back default.
5. Use +/- button to set control switch.
6. Press EXIT after setting.

(5). TRIM OFFSET SETTING



This function is to adjust the servo trim at hovering state. This function is used to automatically change the trim of a helicopter, for example, when transitioned from hover to flying at high speed. A clockwise-rotation rotor helicopter tends to drift to the right at high speed, so an aileron offset may be applied to offset the helicopter to the left.

The necessary elevator offset varies with model geometry, so it must be determined by noting collective pitch changes at high speed.

The rudder offset is affected by both revolution mixing and trim lever movement while in the offset function.

Setting Method:

Use up/down button to select **Trim offset setting**, OK button is to enter editing.

Steps:

1. Use direction buttons to select editing part.
2. Use +/- button to active or inhibit "Mix".
3. Use +/- button to set the control switch "CTRL".
4. Use +/- button to set the control switch position "Pos".
5. Use +/- button to set the channel, eg: aileron, elevator, etc.
6. Use +/- button to set the mix rate "Rate". Press OK button for seconds can back default.
7. Press EXIT after setting.

(6). DELAY

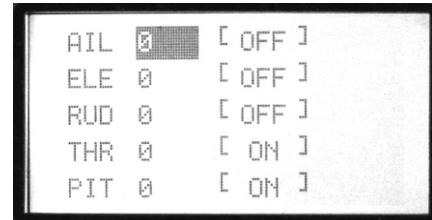

This function is to delay the aerobatics or throttle cut when the helicopter is in the air so that to avoid the big trim change. The Delay function provides a smooth transition between the trim positions whenever OFFSET, REVO. MIXING, or THROTTLE HOLD functions are turned on and off.

Setting Method:

Use up/down button to select **DELAY**, OK button is to enter editing.

Steps:

1. Use direction buttons to select editing part.
2. Use +/- button to active or inhibit this function. Press OK button for seconds can back default.
3. Press EXIT after setting.

(7). GOVERNOR MIXING

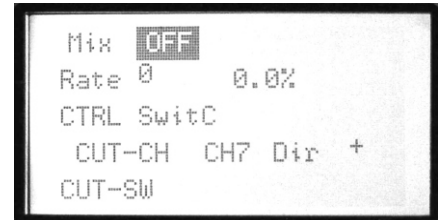

This function is to set the governor.
The Governor mixing function is used to adjust the Governor speed settings from the transmitter.

Setting Method:

Use up/down button to select **Governor mixing**, OK button is to enter editing.

Steps:

1. Use direction buttons to select editing part.
2. Use +/- button to active or inhibit "Mix".
3. Use +/- button to set the mix rate "Rate". Press OK button for seconds can back default.
4. Use +/- button to set the control switch "CTRL".
5. Use +/- button to set the channel and its direction.
6. Press EXIT after setting.

(8). SWASH AND THR MIXING

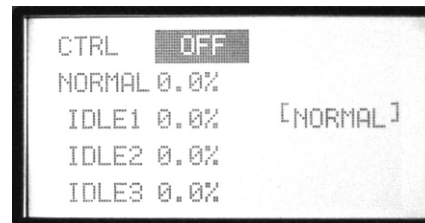

This function is to adjust throttle and pitch mix function.

Setting Method:

Use up/down button to select **Swash and THR mixing**, OK button is to enter editing.

Steps:

1. Use direction buttons to select editing part.
2. Use +/- button to active or inhibit "Mix".
3. Press EXIT after setting.

(9). CURVE SETTING

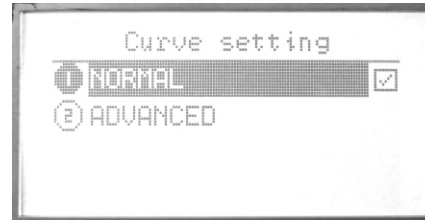

There are 2 kinds of setting, Normal and Advanced.
Please refer to page 25.

(10)-(16). PROG. NOR. MIX1-7



The mix program is to adjust the flying pose. There are 7 series programs with the same setting method. You can set one mix and one mix with another one mix.

Setting Method

Use up/down button to select **PROG. NOR. MIX**, OK button is to enter editing.

Steps:

1. Use direction buttons to select editing part. Set any two channels mix.
2. Use +/- button to active or inhibit "Mix".
3. Use +/- button to active or inhibit "Link" and "TRIM".
4. Use +/- button to active or inhibit "CTRL".
5. Use +/- button to set the control switch position.
6. Press EXIT after setting.

(17)-(20). PROG. CUR. MIX1-4

There are 4 curve mix program, the curve is made up by 2 to 11 point.

Setting Method:

Use up/down button to select **PROG. CUR. MIX**, OK button is to enter editing.

Steps:

1. Use direction buttons to select editing part. Set any two channels mix.
2. Use +/- button to active or inhibit "Mix".
3. Use +/- button to active or inhibit "Link" and "TRIM".
4. Use +/- button to active or inhibit "CTRL".
5. Use +/- button to set the control switch position.
6. Set the curve point.(Normal/Advanced). Please refer to page 25.
7. Press EXIT after setting.

(21). THROTTLE NEEDLE MIXING

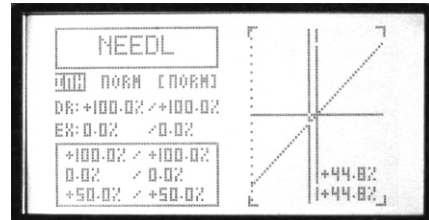

Throttle needle is a pre-programmed mix that automatically moves an in-flight mixture servo in response to the Throttle Stick inputs for perfect engine tuning at all throttle settings. This function is particularly popular with contest pilots who fly in a large variety of locations, needing regular engine tuning adjustments, and requiring perfect engine response at all times and in all maneuvers. Also popular to minimize flooding at idle of inverted engine installations or installations with a high tank position. Not need for fuel injection engine, which do this automatically.

Setting Method

Use up/down button to select **Throttle needle mixing**, OK button is to enter editing.

Steps:

1. Use +/- button to active or inhibit this function.
2. Use +/- button to select one curve. There're 3 curves, NORM, IDLE1, IDLE3.
3. Use direction button to select "D/R"
Edit one or two parameter.
+/- buttons can increase or decrease the value.
Press the OK button is to back default.
4. Use direction button to select "EX"
Edit one or two parameter.
+/- buttons can increase or decrease the value.
Press the OK button is to back default.
EX can adjust aileron, throttle, rudder sensitivity when the sticks are around the middle.
There are a lot of mixes when "D/R" and "EX" come together.
5. Curve setting method please refer to page 25.

AIRPLANE

Press Menu and turn on the transmitter to enter SYS SETTING.
Select MODEL SETTING, press OK button to select the model type.
Restart the transmitter after setting.

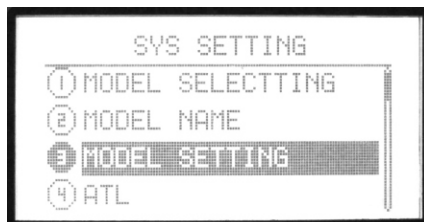

Editing mode and function introduction

1. Opening Screen

Turn on the power switch, the LCD displays as follows.

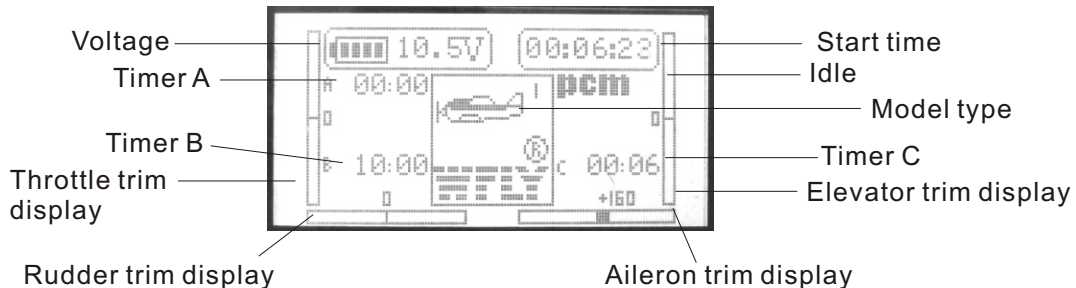

The opening screen displays the voltage, timer, model, aileron, throttle, elevator and rudder state.

Note: Press EXIT you can see the model name.

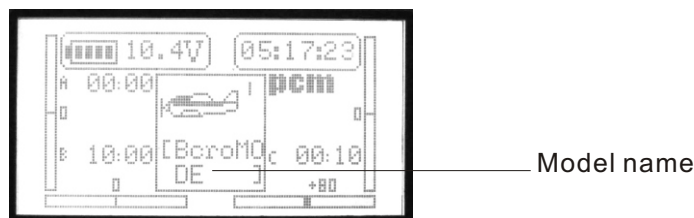

2. Menu Screen

There are “NORMAL SETTING”, “SYS SETTING”, “ADVANCED”.

A. NORMAL SETTING

Turn on the transmitter, press the menu button, the LCD displays as follows.

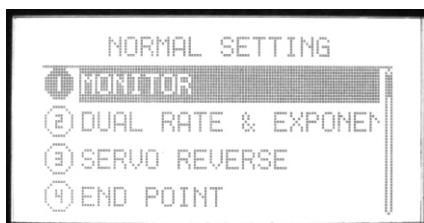

Setting method:

- Use direction button to select the editing part, use up/down buttons to select function item. Left/right direction button to turn page.
- Press OK button to enter submenu. The submenu function is in the next chapter.
- Press EXIT button to back previous menu and the data is set automatically.

- MONITOR
- DUAL RATE & EXPONENTIAL SETTING
- SERVO REVERSE
- END POINT
- SUB TRIM
- AUXILIARY CHANNELS SETTING
- THROTTLE CURVE SETTING
- TRIM STEP SETTING
- FLAPERON
- FLAP TRIM
- AIL-DIFF
- ELEV-FLAP
- THROTTLE CUT SETTING
- IDLE DOWN
- FAIL SAFE
- TIMER
- ADVANCED
- LANGUAGE

B. SYS SETTING

Press Menu and turn on the power switch, the LCD displays as follows.

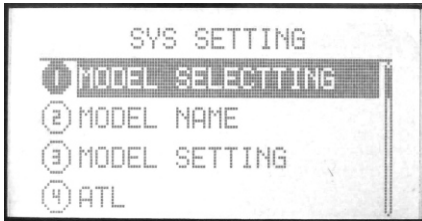

1. MODEL SELECTTING
2. MODEL NAME
3. MODEL SETTING
4. ATL
5. AIL-2
6. MODULATION SETTING
7. STICK SETTING
8. REST SETTING
9. SEND DATA
10. RECEIVE DATA
11. CONTRAST SETTING
12. ENGINEER MODEL
13. ABOUT
14. LANGUAGE

Setting method:

1. Use direction button to select the editing part, use up/down buttons to select function item. Left/right direction button to turn page.

2. Press OK button to enter submenu. The submenu function is in the next chapter.

3. Press EXIT button to back previous menu and the data is set automatically.

C. ADVANCED

1. Enter "NORMAL SETTING", use right direction button to turn page, select "ADVANCED".

Press OK button to enter.

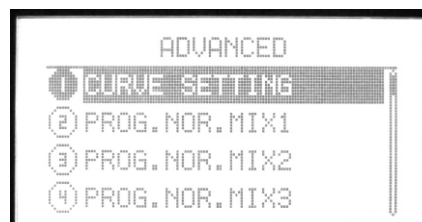

Setting method:

1. Use direction button to select the editing part, use up/down buttons to select function item. Left/right direction button to turn page.

2. Press OK button to enter submenu. The submenu function is in the next chapter.

3. Press EXIT button to back previous menu and the data is set automatically.

SYS SETTING

1.MODEL SELECTTING

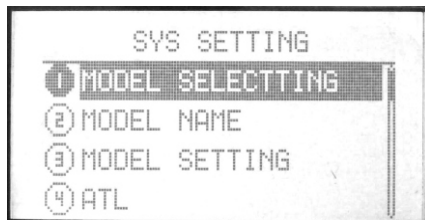

There are 10 airplane models. You can select any one to set.

Setting Method:

Press Menu and turn on the transmitter to enter "SYS SETTING"
Use up/down button to select "**MODEL SELECTTING**", OK button is to enter editing.

Steps:

1. Use up/down direction button to select the model.
2. Press OK button to select.
3. Press EXIT after setting.

2. MODEL NAME

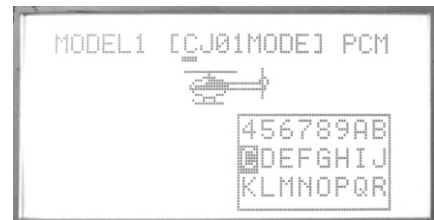
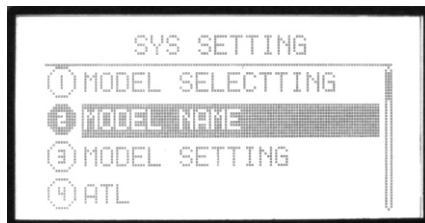

This function is to make new names by users.

Setting Method:

Press Menu and turn on the transmitter to enter "SYS SETTING"
Use up/down button to select "**MODEL NAME**", OK button is to enter editing.

Steps:

1. You can edit the underlined letter.
2. Press OK button to choose the word you like.
3. Press EXIT after setting.

3. MODEL SETTING

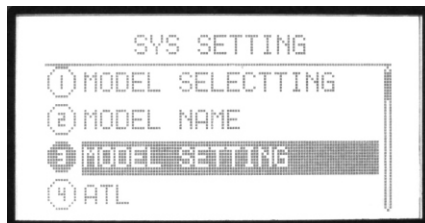

You can select the model type. There are three type: HELI, ACRO, GLID.

Setting Method:

Press Menu and turn on the transmitter to enter “SYS SETTING”
Use up/down button to select “**MODEL SETTING**”, OK button is to enter editing.

Steps:

1. Use up/down direction button to select the model type.
2. Press OK button to confirm.
3. Press EXIT after setting.

4. ATL

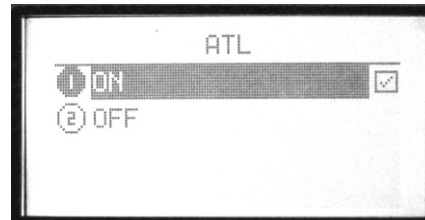
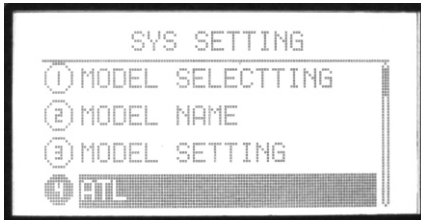

Adjustable travel limit (ATL) makes throttle trim effective only at low throttle, disabling the trim at high throttle. This prevents pushrod jamming due to idling trim changes. This function defaults to ON. If you are not using channel 3 for throttle, you may want trim operation the same as on all other channels. To do so, set ATL to OFF.

Setting Method:

Press Menu and turn on the transmitter to enter "SYS SETTING"
Use up/down button to select "**ATL**", OK button is to enter editing.

Steps:

1. Use direction buttons to select the editing part.
2. Press +/- button to set ATL function.
3. Press EXIT after setting.

5. AIL-2

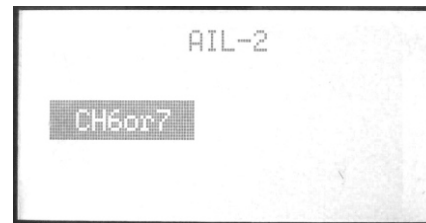
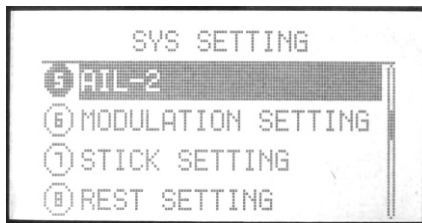

AIL-2 is another channel for aileron.

Setting Method:

Press Menu and turn on the transmitter to enter "SYS SETTING"
Use up/down button to select "AIL-2", OK button
is to enter editing.

Steps:

1. Use direction buttons to select.
2. Press OK button to confirm.
3. Press EXIT after setting.

6. MODULATION SETTING



Because of the different receiver modulation PPM/PCM, the transmitter should be accordance with the receiver modulation.

Setting Method:

Press Menu and turn on the transmitter to enter "SYS SETTING"
Use up/down button to select "**Modulation setting**", OK button is to enter editing.

Steps:

1. Use direction buttons to select the editing part.
2. Press OK button to confirm. Restart the transmitter and it works.

7. STICK SETTING

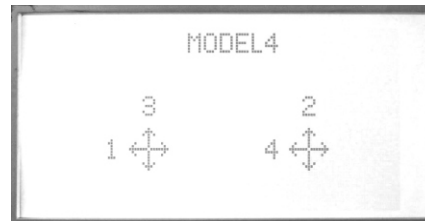
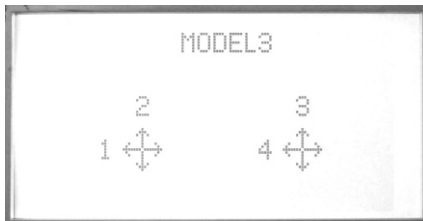
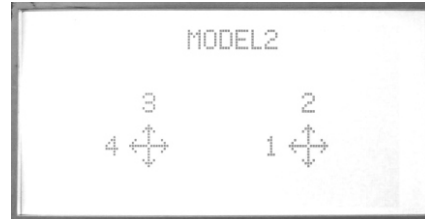
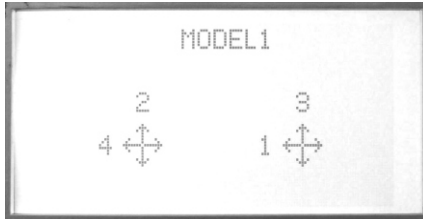

There are 4 kinds of model, you can use up/down direction button to select the model you preferred.

- 1-aileron
- 2-elevator
- 3-throttle
- 4-rudder

Setting Method:

Press Menu and turn on the transmitter to enter "SYS SETTING"
Use up/down button to select "**STICK SETTING**", OK button is to enter editing.

Steps:

1. Use direction button to select the editing part.
2. Press up/down button to choose Stick mode.
3. Press EXIT after setting.

8.REST SETTING

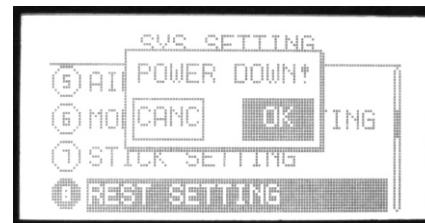

This function is to back default.

Setting Method:

Press Menu and turn on the transmitter to enter "SYS SETTING"
Use up/down button to select "**REST SETTING**", OK button is to enter editing.

Steps:

1. Use direction button to select the editing part.
2. Press +/- button to back default.
3. Press EXIT after setting.

9. SEND DATA

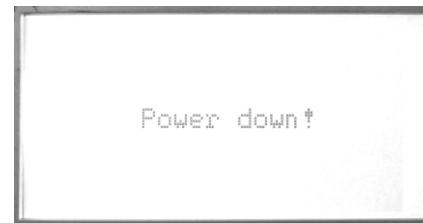
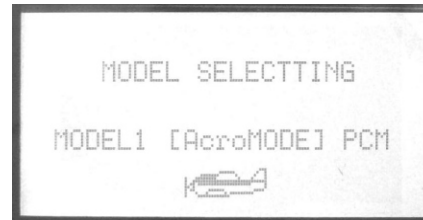
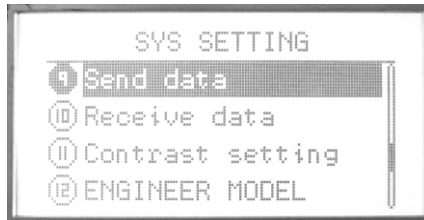

Two transmitters (WFT09) can copy data by a trainer cable/data transfer cable. This function together with the next function “Receive data” can realize the data copy.

Setting Method:

Press Menu and turn on the transmitter to enter “SYS SETTING”
Use up/down button to select “**SEND DATA**”, OK button is to enter editing.

Steps:

1. Select the model data you want to send out.
2. Press OK to send.

10.RECEIVE DATA

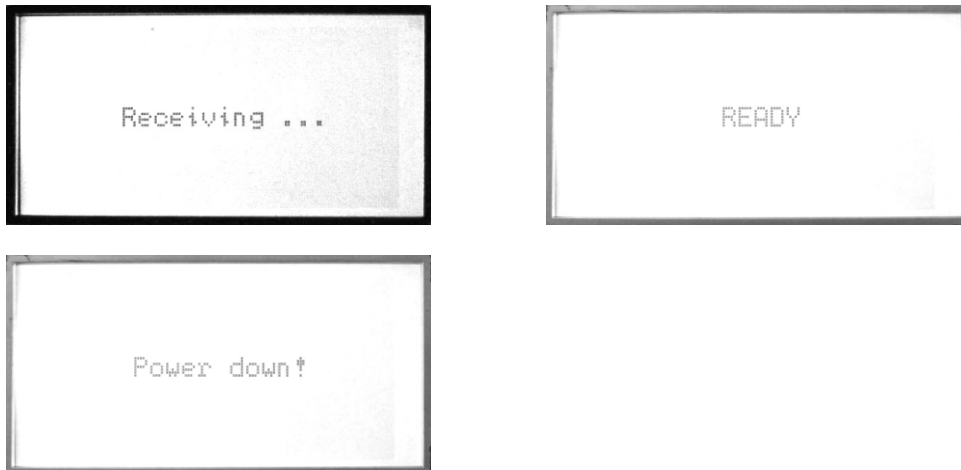

Two transmitters (WFT09) can copy data by a trainer cable/data transfer cable. This function together with the previous function “Send data” can realize the data copy.

Setting Method:

Press Menu and turn on the transmitter to enter “SYS SETTING” Use up/down button to select “**RECEIVE DATA**”, OK button is to enter editing.

Steps:

1. Press OK to receive data.
2. Restart the transmitter after receiving the data and it works.

11.CONTRAST SETTING

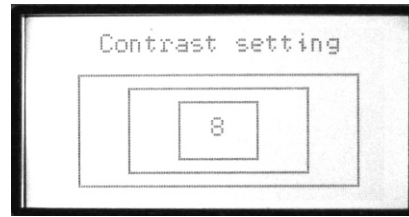
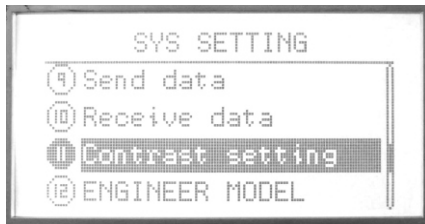

This function is to adjust the LCD brightness by increasing or decreasing the contrast value.

Setting Method:

Press Menu and turn on the transmitter to enter "SYS SETTING"
Use up/down button to select "**RECEIVE DATA**", OK button is to enter editing.

Steps:

1. Use +/- button to increase or decrease the value.
2. Press OK button for a while is to back default.
3. Press EXIT after setting.

14.LANGUAGE

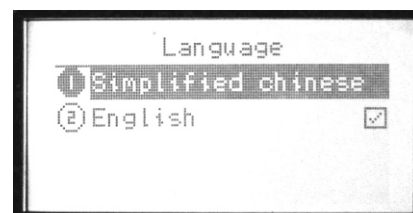

This function is to select the language, Simplified Chinese and English can be selected.

NORMAL SETTING(AIRPLANE)

1. MONITOR

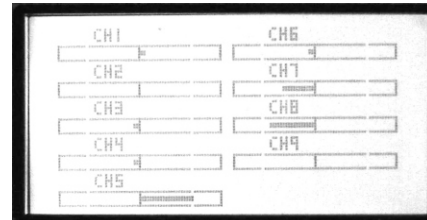
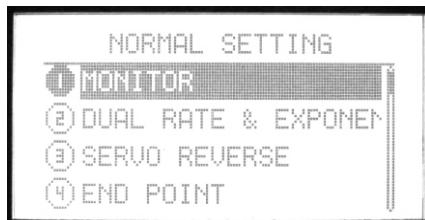

Monitor shows the servos' movement situation.

In PCM, this function is to describe the 9 channels output.

In PPM, this function is to describe the first 7 channels output.

Setting Method:

Press menu button, enter system setting, the first function is the monitor.

2. DUAL RATE & EXPONENTIAL SETTING

(1). AIL

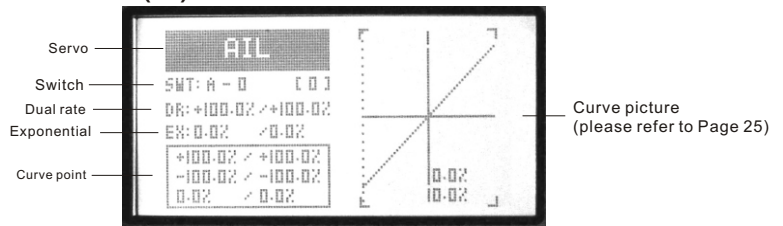

(2). ELE

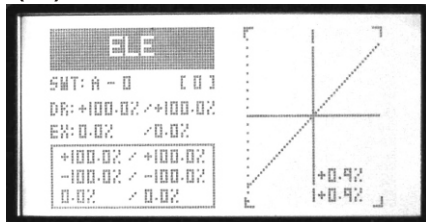

(3). RUD

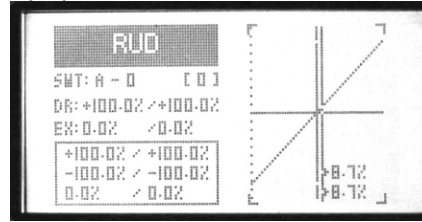

Dual rate is to adjust aileron, elevator and rudder travel range. The range is between 0%-120%.

Exponential setting is to adjust aileron, elevator and rudder sensitivity when the sticks are around the middle. The range is between -100% to +100%.

Setting Method:

1. Select channel

Aileron, elevator and rudder are selectable. Press +/- buttons to select channel, OK button to finish setting.

2. Set the switch and its position(0,1,2)

Press direction button to select "SWT", edit it. +/- buttons can select function switch(A-F).

After selecting the function switch, press right direction button to enter the switch position setting, use +/- buttons to set.

3. Set dual rate

Press direction button to select "D/R", edit it. Edit one or two parameter.

+/- buttons can increase or decrease the value.

Press the OK button is to back default.

4. Set exponential

Press direction button to select "EX". Exponential can adjust aileron, throttle and rudder sensitivity as the stick at the middle.

5. Set curve point (normal/advanced)

The box under "EX" shows the curve points.

Select "Curve setting" in More setting function list.

Please refer to Page 25 for detail curve setting.

6. Press EXIT after all the values are finished setting.

3. SERVO REVERSE

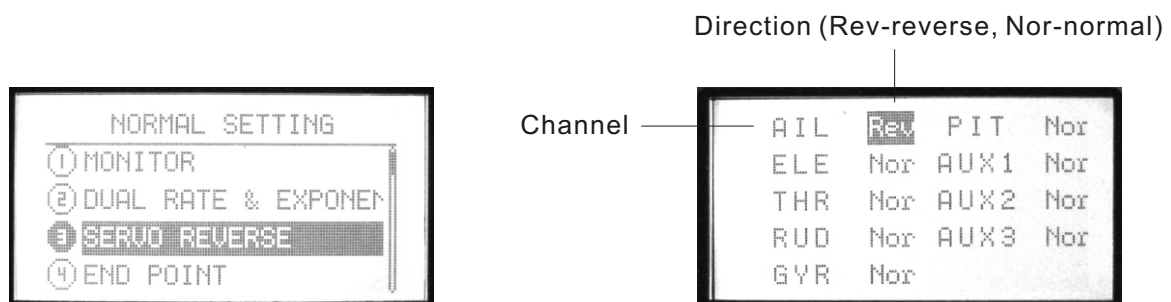

This function is to change the direction of the servos movement.

Setting Method:

Use up/down button to select **SERVO REVERSE**, OK button is to enter editing.

Steps:

1. Use direction buttons to select editing part.
2. Use +/- button or OK button to switch the servo movement direction.
3. Press EXIT after setting.

4. END POINT

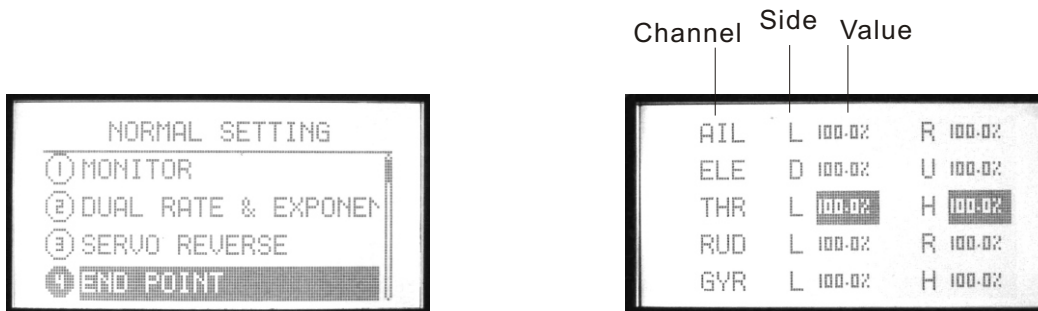

It is to adjust the end of individual servo's travel. The range is from 0% to 120%.

Setting Method:

Use up or down button to select **END POINT**, OK button is to enter editing.

Steps:

1. Use direction buttons to select editing part.
2. Use +/- button or OK button to set the travel value. Press OK for a while backs to default.
3. Press EXIT after setting.

5. SUB TRIM



Sub trim makes small changes or corrections to the neutral position of each servo. Range is -120 to +120, default setting is 0.

We recommend that you center the digital trims before making Sub trim changes, and that you try to keep all of the Sub trim values as small as possible. Otherwise, when the Sub trims are large values, the servo's range of travel is restricted on one side.

Setting Method:

Use up or down button to select **SUB TRIM**, OK button is to enter editing.

Steps:

1. Use direction buttons to select editing part.
2. Use +/- button or OK button to set the trim value. Press OK for a while backs to default.
3. Press EXIT after setting.

6. AUXILIARY CHANNELS SETTING

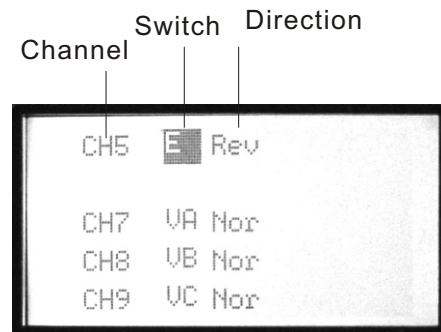
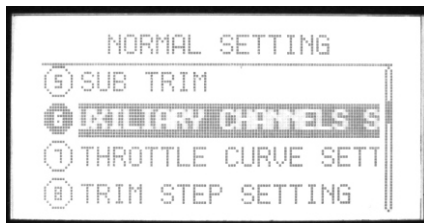

This function is for channel 5 to channel 9 function setting.

Setting Method:

Use up or down button to select **AUXILIARY CHANNELS SETTING**, OK button is to enter editing.

Steps:

1. Use direction buttons to select editing part.
2. Use +/- button to set the switches or knobs. The switches can be set from A to F, the knobs can be set as VA, VB, VC, VL, VR or none(-).
3. Use left or right direction button to set normal or reverse direction of every channel.
4. Press EXIT after setting.

7. THROTTLE CURVE SETTING

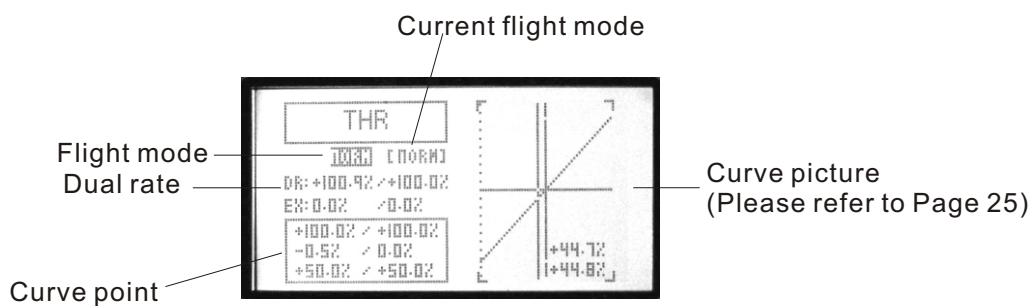

Throttle curve, together with the throttle stick, can be adjusted properly to maximize engine performance at a particular pitch setting.

There are two kinds of curve setting, normal (7 points curve), advanced (2-11 points curve), the range is between 0%-120%. The transmitter can set the following curves: NORM, IDLE1, IDLE2, IDLE3.

Normal curve is based on hovering, to maximize engine performance at a particular pitch setting.

Idle curve is for engine proper work in a 3D flight, with a good match between throttle and pitch.

Setting Method:

Use up/down button to select **THROTTLE CURVE SETTING**, OK button is to enter editing.

Steps:

1. Flight(NORM IDLE1 IDLE2 IDLE3)
Use direction buttons to select editing part. Use +/- button to select one curve.
2. Set Dual rate
Use direction button to select "D/R" and edit (one or two values can be set separately or together). Press +/- button for seconds can increase or delete the value. Press OK button for seconds is to back default(60%).
3. Curve point setting(Normal/Advanced)
The below pane shows the points curve.
Select "Curve setting" in "SYS setting", choose the curve.
For detail curve setting method please refer to Page 25.
4. Press EXIT after setting.

8. TRIM STEP SETTING

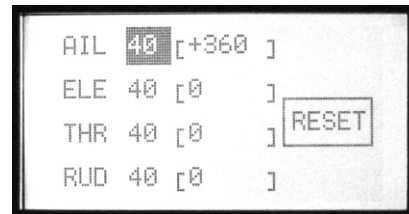

This function is to change the rate at which the trim moves when the TRIM LEVER is activated. The range is from 0 to 250. Generally larger trim steps are for models with larger control throws or for first flights to ensure sufficient trim to properly correct the model. Smaller trim steps are later used to allow very fine adjustments in flight.

Setting Method:

Use up/down button to select **TRIM STEP SETTING**, OK button is to enter editing.

Steps:

1. Use direction buttons to select editing part.
2. Use +/- button to adjust the size of the step. Repeat as desired for other channels. If you select RESET, the current channel trim value change to 0.
3. Press EXIT after setting.

9. FLAPERON

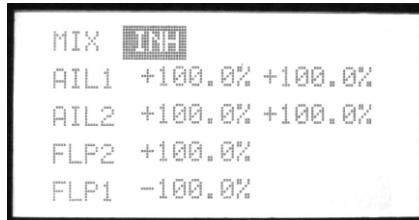

FLAPERON mixing function uses on servo on each of the two ailerons, and uses them for both aileron and flap function.

Setting Method:

Use up/down button to select **FLAPERON**, OK button is to enter editing.

Steps:

1. Use direction buttons to select editing part.
2. Use +/- button to set value. Press OK button for seconds can back default.
3. Press EXIT after setting.

10. FLAP TRIM

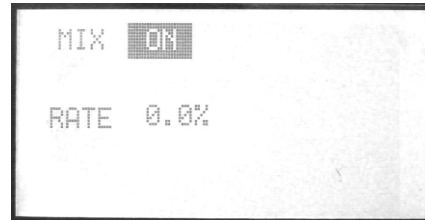

FLAP TRIM assigns the primary flaperon control to allow trimming in flight of the flap action of flaperons.

Setting Method:

Use up/down button to select **FLAP TRIM**, OK button is to enter editing.

Steps:

1. Use direction buttons to select editing part.
2. Use +/- button to set value. Press OK button for seconds can back default.
3. Press EXIT after setting.

11. AIL-DIFF

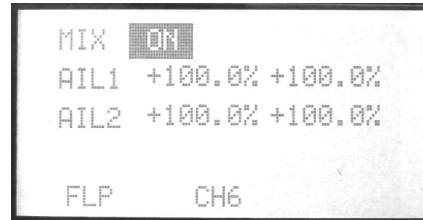

Aileron differential(AIL-DIFF) is primarily used on 3-servo wings, with one servo operating inboard flap(s) on Ch6, and AIL-DIFF controlling proper aileron operation of 2 aileron servos, plugged into Ch1 and Ch7.

Setting Method:

Use up/down button to select **AIL-DIFF**, OK button is to enter editing.

Steps:

1. Use direction buttons to select editing part.
2. Use +/- button to set value. Press OK button for seconds can back default.
3. Press EXIT after setting.

12. ELEV-FLAP

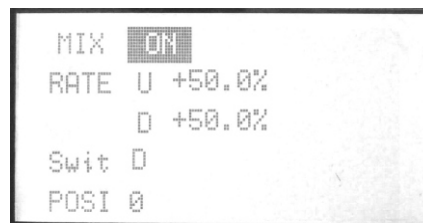

ELEV-FLAP mixing is the first pre-programmed mix we'll cover. This mix makes the flaps drop or rise whenever the elevator stick is moved. It is most commonly used to make tighter pylon turns or squarer corners in maneuvers. In most cases, the flaps droop (are lowered) when up elevator is commanded.

Setting Method:

Use up/down button to select **ELEV-FLAP**, OK button is to enter editing.

Steps:

1. Use direction buttons to select editing part.
2. Use +/- button to set value. Press OK button for seconds can back default.
3. Press EXIT after setting.

13. THROTTLE CUT SETTING

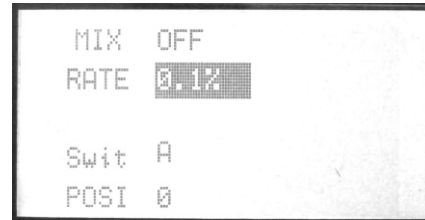
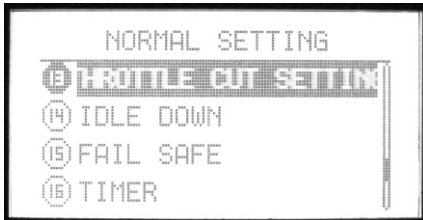

This function is to shut off the engine at the end of a flight. The engine can be stopped with one touch of any switch, eliminating the need to move the trim to kill the engine and then readjust prior to each flight. The helicopter THR CUT includes an ON/OFF throttle position (normally a little above idle). You must move the THROTTLE STICK back below the set point before the THR-CUT function can be reset, to avoid sudden engine acceleration.

Setting Method:

Use up/down button to select **THROTTLE CUT SETTING**, OK button is to enter editing.

Steps:

1. Use direction buttons to select editing part.
2. Use +/- button to turn on/off throttle cut function.
3. Use +/- button to set the throttle rate and trim (range is between +45% to -45%).
4. Use +/- button to set the position.
5. Press EXIT after setting.

14. IDLE DOWN

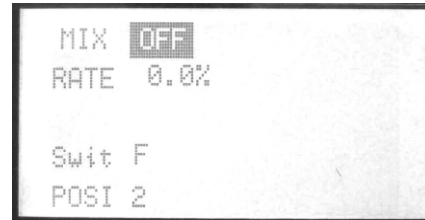
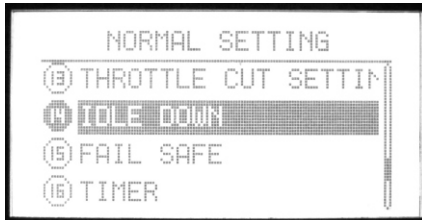

This function is to lower the engine idle for: sitting on the runway prior to take off, stalls and spins, and landings. The normal idle setting is a little higher for easier starts and safe flights with less risk of dead sticks.

The idle down function is not normally used when starting the engine, and its accidental operation may keep your engine from starting.

Setting Method:

Use up/down button to select **IDLE DOWN**, OK button is to enter editing.

Steps:

1. Use direction buttons to select editing part.
2. Use +/- button to set value. Press OK button for seconds can back default.
3. Press EXIT after setting.

15. FAIL SAFE

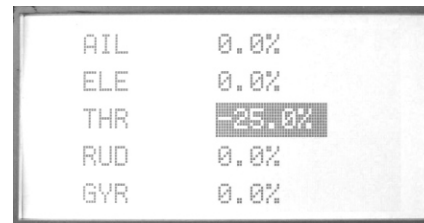
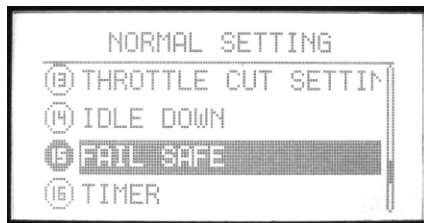

This function is to set responses in case of loss of signal or low RX battery.

Setting Method:

Use up/down button to select **FAIL SAFE**, OK button is to enter editing.

Steps:

1. Use direction buttons to select editing part.
2. Use +/- button to select "hold" or "0.0%"
3. Press OK button to confirm the current parameter.
4. Press EXIT after setting.

16. TIMER

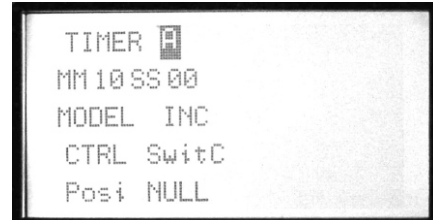

The flight time of every helicopter is different according to the different tank of fuel, engine, ESC, etc. Timer function can alarm you to land before the fuel lacks.

The transmitter can set 3 timers (A, B, C). The longest time can be set as MM99SS59. The countdown timer can alarm user before 10 minutes. The alarm will become 2S/1S from 1S/1S in the last 10 seconds. When the countdown timer is 0, the time will add up.

The timer can be seen in the opening screen. Any switch can be set to control the begin and stop of the time.

Setting Method:

Use up/down button to select **TIMER**, OK button is to enter editing.

Steps:

1. Use direction buttons to select editing part.
2. Set timer. WFT09 can set 3 timers (A, B, C).
3. Use +/- button to set MM..SS... Press OK button for seconds can back to default.
4. Use +/- button to set model.
5. Use +/- button to set control(CTRL).
6. Use +/- button to set the position which can active this function.
7. Press EXIT after setting.

18. Language



This function is to select the language, Simplified Chinese and English can be selected.

17. ADVANCED



To realize an idea fly, there are 20 advanced function in ADVANCED.

Setting Method:

Use up/down button to select ADVANCED, OK button is to enter editing. +/- button can turn page.
About each advanced functions please read the following pages.

ADVANCED function introduction

(1). CURVE SETTING

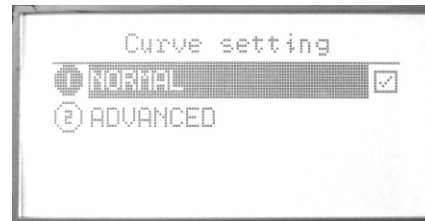

There are 2 kinds of setting, Normal and Advanced.
Please refer to page 25.

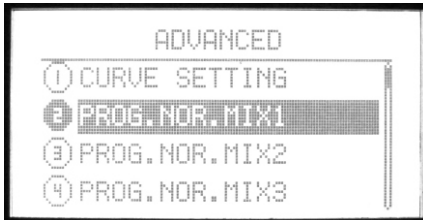
(2)-(8). PROG. NOR. MIX1-7

The mix program is to adjust the flying pose. There are 7 series programs with the same setting method. You can set one mix and one mix with another one mix.

Setting Method

Use up/down button to select **PROG. NOR. MIX**, OK button is to enter editing.

Steps:

1. Use direction buttons to select editing part. Set any two channels mix.
2. Use +/- button to active or inhibit "Mix".
3. Use +/- button to active or inhibit "Link" and "TRIM".
4. Use +/- button to active or inhibit "CTRL".
5. Use +/- button to set the control switch position.
6. Press EXIT after setting.

(9)-(12). PROG. CUR. MIX1-4

There are 4 curve mix program, the curve is made up by 2 to 11 point.

Setting Method:

Use up/down button to select **PROG. CUR. MIX**, OK button is to enter editing.

Steps:

1. Use direction buttons to select editing part. Set any two channels mix.
2. Use +/- button to active or inhibit "Mix".
3. Use +/- button to active or inhibit "Link" and "TRIM".
4. Use +/- button to active or inhibit "CTRL".
5. Use +/- button to set the control switch position.
6. Set the curve point.(Normal/Advanced). Please refer to page 25.
7. Press EXIT after setting.

(13). AIR BRAKE

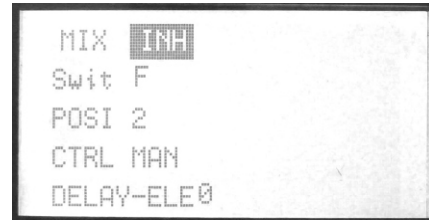

AIR BRAKE simultaneously moves the flaps, twin ailerons and elevators, and is usually used to make steep descents or to limit increases in airspeed in dives.

Setting Method:

Use up/down button to select **AIR BRAKE**, OK button is to enter editing.

Steps:

1. Use direction buttons to select editing part.
2. Use +/- button to active or inhibit "Mix".
3. Use +/- button to set Swit, POSI. Press OK button for seconds can back default.
4. Use +/- button to set CTRL (MAN/ THR).
5. Use +/- button to set delay value. Press OK button for seconds can back default.
6. Press EXIT after setting.

(14). ELEVON

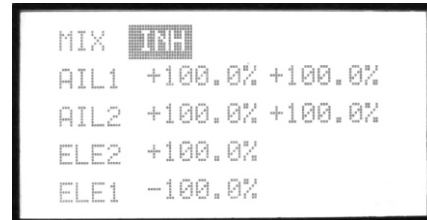
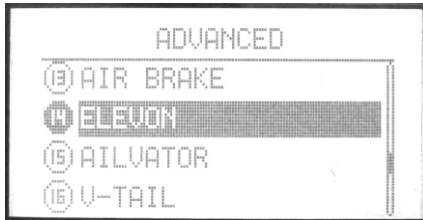

This function used with delta wings, flying wings, and other tailless aircraft that combine aileron and elevator functions, using two servos, one on each elevon. The aileron/elevator responses of each servo can be adjusted independently.

Setting Method:

Use up/down button to select **ELEVON**, OK button is to enter editing.

Steps:

1. Use direction buttons to select editing part.
2. Use +/- button to set value. Press OK button for seconds can back default.
3. Press EXIT after setting.

(15). AILVATOR

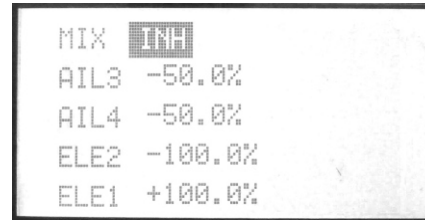
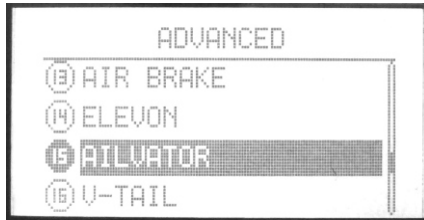

AILEVATOR mixing function uses one servo on each of the two elevators, and combines the elevator function with the aileron function(unless aileron travel is set to 0).

Setting Method:

Use up/down button to select **AILVATOR**, OK button is to enter editing.

Steps:

1. Use direction buttons to select editing part.
2. Use +/- button to set value. Press OK button for seconds can back default.
3. Press EXIT after setting.

(16). V-TAIL

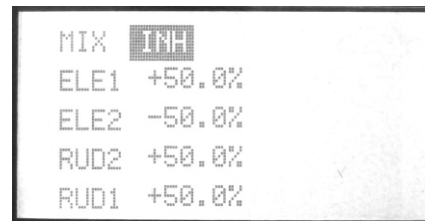

V-TAIL mixing is used with v-tail aircraft so that both elevator and rudder functions are combined for the two tail surfaces. Both elevator and rudder travel can be adjusted independently on each surface.

Setting Method:

Use up/down button to select **V-TAIL**, OK button is to enter editing.

Steps:

1. Use direction buttons to select editing part.
2. Use +/- button to set value. Press OK button for seconds can back default.
3. Press EXIT after setting.

(17). SNAP-ROLL

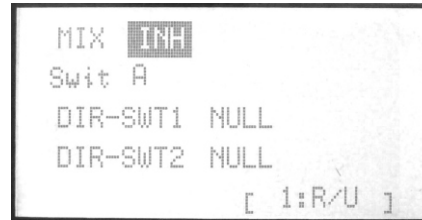
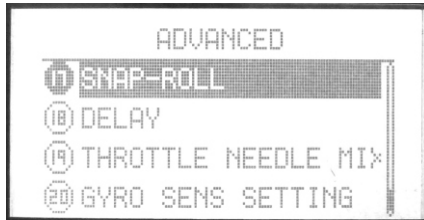

This function allows you to execute snap rolls by flipping a switch, providing the same input every time. It also removes the need to change dual rates on the 3 channels prior to performing a snap, as snap-roll always takes the servos to the same position, regardless of dual rates, inputs held during the snap, etc.

Setting Method:

Use up/down button to select **SNAP-ROLL**, OK button is to enter editing.

Steps:

1. Use direction buttons to select editing part.
2. Use +/- button to set value. Press OK button for seconds can back default.
3. Press EXIT after setting.

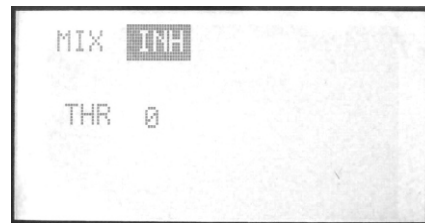
(18). DELAY

DELAY function is used to slow the response of the throttle servo to simulate the slow response of a turbine engine.

Setting Method:

Use up/down button to select **DELAY**, OK button is to enter editing.

Steps:

1. Use direction buttons to select editing part.
2. Use +/- button to active or inhibit this function. Press OK button for seconds can back default.
3. Press EXIT after setting.

(19). THROTTLE NEEDLE MIXING

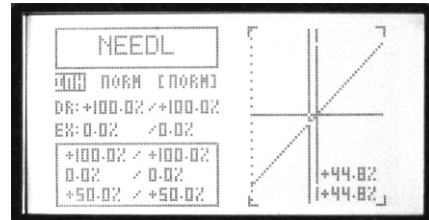
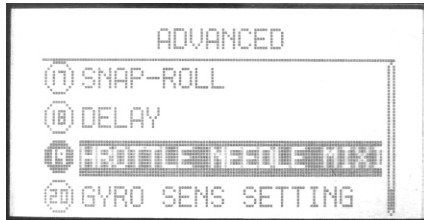

Throttle needle is a pre-programmed mix that automatically moves an in-flight mixture servo in response to the Throttle Stick inputs for perfect engine tuning at all throttle settings. This function is particularly popular with contest pilots who fly in a large variety of locations, needing regular engine tuning adjustments, and requiring perfect engine response at all times and in all maneuvers. Also popular to minimize flooding at idle of inverted engine installations or installations with a high tank position. Not need for fuel injection engine, which do this automatically.

Setting Method

Use up/down button to select **Throttle needle mixing**, OK button is to enter editing.

Steps:

1. Use +/- button to active or inhibit this function.
2. Use +/- button to select one curve. There're 3 curves, NORM, IDLE1, IDLE3.
3. Use direction button to select "D/R"
Edit one or two parameter.
+/- buttons can increase or decrease the value.
Press the OK button is to back default.
4. Use direction button to select "EX"
Edit one or two parameter.
+/- buttons can increase or decrease the value.
Press the OK button is to back default.
EX can adjust aileron, throttle, rudder sensitivity when the sticks are around the middle.
There are a lot of mixes when "D/R" and "EX" come together.
5. Curve setting method please refer to page 25.

(20). GYRO SENS SETTING

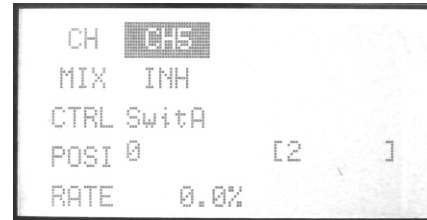
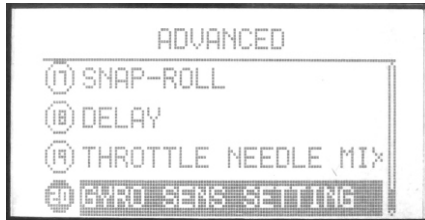

User can adjust the gyro sensitivity by transmitter, AVCS gyro (GY) and normal gyro (STD).

Gyro sensitivity switch plug should plug in the fifth channel of receiver. The auxiliary channel CH 5 won't have any function now. User can set sensitivity switch from switch A to F, and also fly model (NORM, IDLE1,2,3).

Setting Method:

Use up/down button to select **GYRO sens setting**, OK button is to enter editing.

Steps:

1. Use direction buttons to select editing part.
2. Use +/- button to set fly model at "MODE".
3. Use +/- button to active or inhibit "Mix". Press OK button for seconds can back default.
4. Use +/- button to set control switch at "CTRL".
5. Use +/- button to set the switch position when the function is active.
6. Use +/- button to set the "Rate". Press OK button for seconds can back default.
7. Press EXIT after setting.

TO THE PILOT

WFT09 is the first version which includes helicopter and airplane function. Thank you for using the radio systems.

We welcome your valuable advice and we will continue developing the radio.

Welcome to contact us!

www.wflysz.com

sales@wflysz.com

Tel: 0086 755 26581817

Fax: 0086 755 26581821



[*www.wflysz.com*](http://www.wflysz.com)