

## HiModel Brushless Speed Controller User Guide

Thank you for purchasing the HIMODEL ESC (electronic speed controller), which is a microprocessor controlled unit developed to be easy to use and configure.

The separate cable and software can also be purchased which allows configuration via a PC as well.

The brushless speed controller is made using the best components and workmanship found in China today.

We would once again like to thank you for purchasing the HIMODEL brushless speed controller and wish you would enjoy using the product as much as we have had designing it!

**We strongly recommend that these safety instructions are read and followed!**

## Contents

1.0	Safety and operating instructions	3
2.0	Limitation of liability	5
3.0	Features of <b>HIMODEL ESC</b>	6
4.0	Wiring your <b>HIMODEL ESC</b>	7
4.1	Servo Ratings with BEC Enabled	7
4.2	Adding the Battery Connector	7
4.3	Connecting the Motor	7
4.4	Reversing Rotation	8
4.5	Connecting the Receiver	8
5	Using your <b>HIMODEL ESC</b> for the first time	9
6	Flying with the <b>HIMODEL ESC</b>	10
7	Using the Programming Features of <b>HIMODEL ESC</b>	11
8	<b>HIMODEL ESC</b> Programming Features	12
9	Entering Programming Mode	13
10	Programming the <b>HIMODEL ESC</b>	14
11	Troubleshooting	16
12	Contact	16

## 1.0 Safety and operating instructions

Building and operating an R/C model aircraft requires experience and knowledge. Incorrect assembly and careless use can result in significant property damage and/or personal injuries. For these reasons please follow the instructions carefully.

The **HIMODEL ESC** is developed exclusively for R/C model applications.

The **HIMODEL ESC** is designed for operation with Ni-Cd, Ni-MH or Li-XX batteries. Never use the unit by connecting to any other power supply. Never connect the **HIMODEL ESC** unit directly or indirectly to the 110V/AC or 230V/AC current.

At all times keep your body and any other objects away from the path of a propeller or other spinning motor parts, when connected to a battery as objects can be projected and/or weaken the propeller and driver, causing mechanical or electrical failure.

Although **HIMODEL ESC** has safety features, taking care is still important.

Never lean over a running system.

Keep anybody, especially small children and animals, at least 20 feet (about 6 meters) away, when operating and/or testing R/C equipment.

Protect the **HIMODEL ESC** against vibration, dust, moisture, impact or pressure. Check the unit regularly for damage. Should the device become wet, only reuse it after drying thoroughly in a warm place and after careful examination. Also check the **HIMODEL ESC** unit completely after any model crash. Never use a damaged **HIMODEL ESC** unit!

The **HIMODEL ESC** can operate at temperatures between 10°C (50°F) and 50°C (122°F). Always ensure the ESC is well ventilated in an aircraft.

**HIMODEL ESC** can be damaged by electrostatic discharge, so please always ensure the soldering iron is earthed when soldering connectors etc.

**HIMODEL ESC** unit is not protected against polarity reversal; therefore you must be sure that polarity is correct when connecting the **HIMODEL ESC** unit. If the connection is the wrong way round the device will be damaged. If you want to reverse the motor rotation, bench test the motor connections, noting the rotation of the motor. To change the rotation of the motor, simply swap any two wires connections to the motor or by programming it. Never reverse the battery connection leads. Never connect battery wires directly to the motor.

Never disconnect the battery from the **HIMODEL ESC** when the motor is running. This can cause high current pulses, which can damage the ESC.

Some systems are fitted with a switch to turn off the receiver, if the batteries are not disconnected from the **HIMODEL ESC** unit a low residual current flows, even if the switch is OFF, this can cause deep discharge of the battery and can damage Lion/Li-Poly cells! Therefore please disconnect the battery from the **HIMODEL ESC** after the end of a run or storing the model.

Never connect a receiver battery in parallel when using the BEC feature of the **HIMODEL ESC**. This will render the BEC device useless! If you want to use a separate receiver battery, then disconnect the red wire from the receiver-lead. The free connector should be insulated with a piece of electrical tape or heat

shrink tube to protect it from short-circuiting. Removing the red lead from the receiver lead will remove the BEC facility and a receiver battery can be connected without any danger. The permissible BEC load, which depends of the cells number and type of the battery pack, is listed below.

Attention! Digital Micro servos have a very high current drain, that means that the indicated number of Servos has, if necessary, to be decreased.

Mount your radio equipment, especially the receiver with its antenna, as far as possible from **HIMODEL ESC** unit, battery and motor. Otherwise, high frequency magnetic fields could affect the receiver. Always do a range test with the motor running at low speed, to make sure of perfect functioning of your model.

For any connection you should use good quality plugs and sockets, which must be soldered perfectly to the wires. Never use strip connectors, crimp connectors or similar.

Connect the **HIMODEL ESC** lead to the throttle channel on your receiver. Don't operate the **HIMODEL ESC** with a servo tester; because it is possible the motor or controller can be damaged due to incorrect "throttle pulses". For this reason we, also, strongly recommend only using receivers from reputable and reliable manufacturers!

**HIMODEL ESC** units are equipped with an extensive protection device, which can only protect when operating in a "normal" fashion. For example if you get a motor winding short-circuiting, or connecting wire short circuit etc, the **HIMODEL ESC** unit could be damaged or destroyed.

## **2.0 Limitation of liability**

HIMODEL and its vendors have no control over the correct use, installation, application, or maintenance of the HIMODEL ESC, no liability shall be assumed nor accepted for any damages, losses or costs resulting from the use of the product. Any claims arising from the operating, failure or malfunctioning etc. will be denied. HIMODEL assumes no liability for personal injury, property damage or consequential damages resulting from our product or our workmanship.

### 3.0 Features of the HIMODEL ESC

HIMODEL ESC unit is a highly developed electronic device, which can, through setting be made compatible to various types of brushless motors. The compact dimensions and low weight make it a good choice for small model aircraft.

For all the different types, which are individually described below, you will find the correct programming for various applications.

The HIMODEL ESC has many powerful features, which include:

- Microprocessor controlled
- User Programmable
- High rate (10 KHz) switching (PWM)
- Six to twelve NiCad, Ni-MH cells or two to four Li-poly cells with receiver
- Up to ten NiCad, Ni-MH cells or three Li-poly cells with three micro servos
- Twelve NiCad, Ni-MH cells or four Li-poly cells MAX (with BEC disabled)
- Dynamic braking ensures prompt prop folding
- BEC (1.0A) provides power to receiver and servos - eliminates the requirement of a separate receiver battery
- Over heat/temperature protection
- Low-voltage protection - the value of low-voltage cutoff can be set.
- Cutoff can be programmed for motor stop or reduced power
- Brake Type
- Throttle Range
- Timing Advance
- Safe "power on" arming program ensures motor will not accidentally turn on
- Low torque "soft start" prevents damage to fragile gearboxes
- Auto shut down in 4sec after when signal is lost or radio interference becomes severe
- Change of motor rotation.

## 4.0 Wiring Your **HIMODEL** ESC

Tools required

1. Wire cutters
2. Wire strippers
3. Soldering Iron

Parts required

1. Solder (rosin core "electronic" solder)
2. Battery connector

### 4.1 Servo Ratings with BEC Enabled

Servo Type	6 cells	7-8 cells	9-10 cells	11-12 cells
Standard (micro) servos	4	4	3	3
High Torque servos	4	3	2	2

### 4.2 Adding the Battery Connector

The battery connector is attached to the side of the controller that has only TWO power wires (black and red), which also has the radio connector.

Cut the wires to the length you require.

Strip off of the wire insulation to expose just enough wire to attach the battery connector. (Note: if you do not have a pair of wire strippers, you can use a modeling knife to careful cut through the insulation around the wire.)

Attach the battery connector to the wires ENSURING THAT THE POLARITY (red wire to battery red wire, black wire to battery black wire) IS CORRECT, following the instructions for the battery connector.

**IMPORTANT NOTE: YOU MUST BE SURE THAT THE POLARITY IS CORRECT WHEN CONNECTING THE SPEED CONTROLLER. INCORRECT POLARITY COULD PERMANENTLY DAMAGE THE CONTROLLER.**

### 4.3 Connecting the Motor

The motor is connected to the side of the controller that has THREE power wires (Red). Cut the wires to the length you require.

**DO NOT CUT** the wires leading from the motor.

Strip the wire insulation to expose just enough wire to solder the wires to the motor leads.

There should be three wires extending from the motor.

Connect the three speed control wires to the three motor wires.

Align the wires carefully and solder to the motor wires.

Ensure that all connections are insulated.

Ensure that all connections (battery and motor) are correctly polarized.

#### 4.4 Reversing Rotation

Bench test the motor connections noting the rotation of the motor. To change the rotation of the motor, you can swap any two motor wire connections or via the programmable the ESC directly or via a PC.

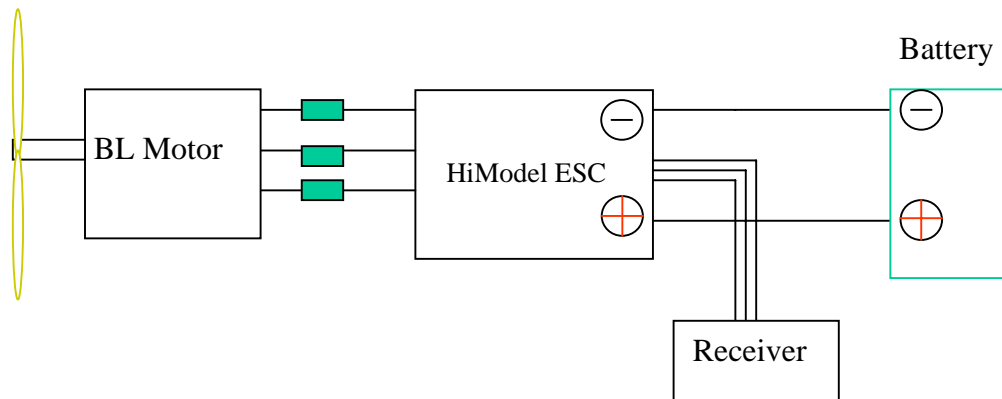

Fig: Motor, Battery and Receiver wiring diagram

Key to illustration:

Receiver cable	3-pin (Futaba J Type Connector) Black
• - = Negative	Black or brown
• + = Positive	Red
• p = pulse	White or orange
Battery connection negative (-)	Black
Battery connection positive (+)	Red
Motor connection a	Red or yellow
Motor connection b	Red or yellow
Motor connection c	Red or yellow

#### 4.5 Connecting the Receiver

Connect the receiver lead (the three color twisted wires with a connector on the end) to the throttle channel on your receiver. Do not connect a battery to the receiver, as the **HIMODEL ESC** will supply power to the receiver and servos through the receiver connector.

If you are using more than twelve cells, you must use a separate receiver battery. See the section 7.0 (under the heading BEC) for instructions on disabling the BEC to use a separate receiver battery.



## 5.0 Using your **HIMODEL ESC** in the first time

The **HIMODEL ESC** controller has been designed to be used with brushless motors. This ESC can be adapted for many battery types, brushless motors, receivers and propellers. It may not suit all types, so please check the specifications of the controller and your choice of motor etc first.

The intelligent programming systems make the **HIMODEL ESC** very powerful and flexible, such as the start-up procedure for example standard controllers can make the propeller pulse the wrong way at first, then change, but the **HIMODEL ESC** controller has a new program which would turn the propeller the correct way from the start. If it starts rough, don't throttle up, wait for a second or two and the ESC will calibrate itself.

A single beep mostly indicates that the controller is armed! When you next move the throttle stick, the motor will start running. If the **HIMODEL ESC** beeps twice when the transmitter stick is at the brake position, you must disconnect the power to the controller and operate the servo reverse facility on your transmitter, otherwise the controller would arm itself (single beep) at the full-throttle setting of your transmitter and would run at full throttle with the stick at the "stopped" position-the exact opposite of what is required.

We advise you to test your system before flying to make sure your system is safe and effective.

## 6.0 Flying with the **HIMODEL ESC**

ALWAYS PERFORM A RANGE CHECK BEFORE FLYING WITH ANY NEW SPEED CONTROLLER!

PERFORM A RANGE CHECK AT FULL THROTTLE, HALF THROTTLE AND NO THROTTLE.

### **Initialization sequence:**

6.1 Connect the speed controller receiver connector to the proper channel on your receiver.

6.2 Turn on your transmitter, and set the throttle stick to closed or lowest position.

6.3 Connect the main power battery to the speed controller, you should hear a "beep", and see the LED "flash" once.

6.4 The speed controller will remain disarmed (will not operate) until it sees more than two seconds of "brake" throttle. Then you will hear a "beep" or double "beep", at the same time, the LED will "flash" once or twice.

One "beep" and one "flash" means no brake, double "beep" and two "flashes" means braking is enabled.

6.5 Now your ESC is operational and you can fly after making sure all servos are set up correctly and secure etc.

If the motor cuts off when you are flying, you must put the throttle to the lowest position, and then you can restart the motor and use low throttle, land your model as soon as you can.

Check your battery voltage, as the BEC will cutoff too if the voltage drops too low.

## 7.0 Using the Features of Your HIMODEL ESC

BEC - BEC power is supplied to the receiver and servos through the receiver connector wires. If you wish to disable the BEC and use a separate receiver battery, you must disconnect the red wire in the receiver wires. Simply use a pair of wire cutters to remove a short section of the red wire near the receiver connector or extract the metal pin from the plastic housing, be sure to insulate the wire with a piece of electrical tape or heat shrink tube. Then you may safely use a separate battery with your receiver.

Brake - moving the transmitter throttle stick to the bottom position enables the prop brake if the program is set correctly.

Cutoff - Motor cutoff will occur when the input battery voltage drops below the programmed cutoff voltage (factory preset at 5.6V) for more than one half second. Once motor cutoff has occurred, moving the throttle to the braking position (full off) can re-arm the controller. This will allow restart of the motor after cutoff has occurred.

WARNING: Repeated restarting of the motor may drain the battery to a point where the radio receiver will stop operating, resulting in a loss of control of the model, and may damage the battery.

Loss of Transmitter Signal, or excessive radio noise - Motor cutoff will also occur if the signal from the transmitter is lost or if radio interference becomes excessive. After radio connection has been re-established, moving the throttle to the brake position (full off) for four seconds will restart the motor.

Safe Power Up - The Safe Power up feature is a "finger saver", designed to prevent the motor from starting accidentally on power up. To arm the controller, the transmitter stick must be held in the "Brake" position (all the way down) for at least four seconds.

**UNTIL THE CONTROLLER IS ARMED, IT WILL NOT PROVIDE ANY POWER TO THE MOTOR, REGARDLESS OF WHERE THE THROTTLE STICK ON YOUR TRANSMITTER IS POSITIONED.**

Before flying your model, be sure to "blip" the throttle to ensure that the controller is armed.

LED - The LED is used to provide an indication that the controller has reached full throttle by lighting brightly when full throttle is reached.

## 8.0 HIMODEL ESC Programming

### Features

Programming the HIMODEL ESC is as simple as answering a few questions. The HIMODEL ESC asks questions by "beeping" a setting number, followed by the possible setting values.

There are five settings that can be programmed in the HIMODEL ESC:

1. Cutoff voltage,
2. Brake Type,
3. Timing Advance,
4. Cutoff Type and
5. Change the rotation of motor.

As the programmer, you must make the choice of the setting values as presented by the HIMODEL ESC. The setting values are "beeped" and "flashed" by the LED. When answering a question, you will need to move the transmitter stick to the full throttle position and keep it there for about 2 seconds. After that, the HIMODEL ESC will return to the programming mode and ask the next question.

You are not required to continue through all five programming options. You can choose what item you want to change in the programming mode and the change will be retained when you leave the programming mode.

## 9.0 Entering Programming Mode

The HIMODEL ESC software is designed to make it difficult to accidentally enter programming mode. This is to prevent entering programming mode while preparing to fly or while in flight.

**To enter programming mode, follow the steps below:**

### 9.1 Verify Normal Operations

If this is the first time the HIMODEL ESC has been used, it is important to verify that the HIMODEL ESC operates normally with your transmitter otherwise programming may not function properly. Follow the instructions in section 6.0 Initialization Sequence (steps 1-4).

Once you have verified that the HIMODEL ESC operates normally, proceed to 9.2 below. If the HIMODEL ESC does not operate properly, see section 11.0, Troubleshooting.

### 9.2 Enter Programming Modes

- Remove battery power from the HIMODEL ESC.
- Move the transmitter stick to the top position (normally full "On").
- Reconnect battery power to the HIMODEL ESC.
- After approximately 2 seconds, the HIMODEL ESC will emit a short tone, and the LED on the HIMODEL ESC will give a short flash, that means power on. Then, after waiting for 5 seconds, you will hear four short "beeps" and six long "beeps", repeated. That means you have entered programming mode.
- As the long "beeps" occur, move your transmitter stick to the lowest position to select an option as in the table below show.

HIMODEL ESC "beep"	Operation	Setting	HIMODEL ESC Responses
Four short "beeps"			
First long "beep"	Put stick to the lowest position	Cutoff voltage	One "beep"
Second long "beep"	Put stick to the lowest position	Brake Type	Two "beeps"
Third long "beep"	Put stick to the lowest position	Timing Advance	Three "beeps"
Fourth long "beep"	Put stick to the lowest position	Cutoff Type	Four "beep"
Fifth long "beep"	Put stick to the lowest position	Change rotation	Five "beeps"
Sixth long "beep"	Put stick to the lowest position	Leave programming mode	Wait 2 seconds for one or two "beeps" (section 8.0)

## 10.0 Programming the HIMODEL ESC

Important Note: When programming the ESC, to select an option you will need to move the transmitter stick to Yes (full "On" throttle) position and keep it there for about 2 seconds. When the HIMODEL ESC has accepted your answer, you will get a response, accepting the change, and then you would be returned to the programming mode.

### 10.1 Programming Setting 1 –Cutoff Voltage

★Factory default settings are indicated by an asterisk in the option listings below.

HIMODEL ESC "beep"	Setting	Recommended for use with	Operation	HIMODEL ESC Responses
one short "beep"				
First long "beep"	4.8V cutoff voltage	6 cell Ni-MH packs	Put stick to the top position	One "beep"
Second long "beep"	★ 5.6V cutoff voltage	7 cell Ni-MH or 2 cell Li-poly packs (per cell 2.8v)	Put stick to the top position	Two "beeps"
Third long "beep"	6.0V cutoff voltage	8 cell Ni-MH or 2 cell Li-poly packs	Put stick to the top position	Three "beeps"
Fourth long "beep"	7.2V cutoff voltage	9 cell Ni-MH	Put stick to the top position	Four "beeps"
Fifth long "beep"	8.4V cutoff voltage	10 cell Ni-MH or 3 cell Li-poly packs (per cell 2.8v)	Put stick to the top position	Five "beeps"
Sixth long "beep"	9.0V cutoff voltage	12 cell Ni-MH or 3 cell Li-poly packs	Put stick to the top position	Six "beeps"
Seventh long "beep"	11.2V cutoff voltage	4 cell Li-poly packs (per cell 2.8v)	Put stick to the top position	Seven "beeps"
Eighth long "beep"	12V cutoff voltage	4 cell Li-poly packs	Put stick to the top position	Eight "beeps"

### 10.2 Programming Setting 2 –Brake Type

HIMODEL ESC "beep"	Setting	Recommended for use with	Operation	HIMODEL ESC Responses
two short "beeps"				
First long "beep"	★No brake		Put stick to the top position	One "beep"
Second long "beep"	Brake		Put stick to the top position	Two "beeps"

### 10.3 Programming Setting 3 –Electronic timing advance

HIMODEL ESC "beep"	Setting	Recommended for use with	Operation	HIMODEL ESC Responses
Three short "beeps"				
First long "beep"	4° ~ 10°	12 or more pole motor and out runner motor	Put stick to the top position	One "beep"
Second long "beep"	★10° ~ 20°	6 or 8 pole motor	Put stick to the top position	Two "beeps"
Third long "beep"	20° ~ 30°	2 or 4 pole motor	Put stick to the top position	Three "beeps"

### 10.4 Programming Setting 4 – Cutoff Type

HIMODEL ESC "beep"	Setting	Recommended for use with:	Operation	HIMODEL ESC Responses
Four short "beeps"				
First long "beep"	Cut off		Put stick to the top position	One "beep"
Second long "beep"	Reduce power		Put stick to the top position	Two "beeps"

### 10.5 Programming Setting 5 – Change the rotation of the motor

HIMODEL ESC "beep"	Setting	Recommended for use with	Operation	HIMODEL ESC Responses
five short "beeps"				
First long "beep"	★			
Second long "beep"		Change rotation	Put stick to the top position	Two "beeps"

### 10.6 Programming Setting 5 – Leave programming mode

Please refer to 9.2.5

## **11.0 Troubleshooting**

If you still require further assistance please contact us via email or on the numbers below.

## **12.0 Contact**

If you have any questions, suggestions or comments please contact us at:

**HiModel Co. Ltd**

R1317 Science & Technology Plaza

236# Liaoning Rd.

Qingdao,

CHINA 266012

Tel: +86 532 83609069

Fax: +86 532 83841601

Website: [www.HiModel.com](http://www.HiModel.com)

Email: [exportrc@yahoo.com](mailto:exportrc@yahoo.com)

Operational times: 1am – 9am GMT